

MM200

High Speed Microwave Modem

Installation and Operation Manual

TM086 - Rev. 4.1





Warranty Policy



Comtech EF Data products are warranted against defects in material and workmanship for a period of two years from the date of shipment. During the warranty period, Comtech EF Data will, at its option, repair or replace products that prove to be defective.

For equipment under warranty, the owner is responsible for freight to Comtech EF Data and all related customs, taxes, tariffs, insurance, etc. Comtech EF Data is responsible for the freight charges only for return of the equipment from the factory to the owner. Comtech EF Data will return the equipment by the same method (i.e., Air, Express, Surface) as the equipment was sent to Comtech EF Data.

All equipment returned for warranty repair must have a valid RMA number issued prior to return and be marked clearly on the return packaging. Comtech EF Data strongly recommends all equipment be returned in its original packaging.

Comtech EF Data Corporation's obligations under this warranty are limited to repair or replacement of failed parts, and the return shipment to the buyer of the repaired or replaced parts.

Limitations of Warranty

The warranty does not apply to any part of a product that has been installed, altered, repaired, or misused in any way that, in the opinion of Comtech EF Data Corporation, would affect the reliability or detracts from the performance of any part of the product, or is damaged as the result of use in a way or with equipment that had not been previously approved by Comtech EF Data Corporation.

The warranty does not apply to any product or parts thereof where the serial number or the serial number of any of its parts has been altered, defaced, or removed.

The warranty does not cover damage or loss incurred in transportation of the product.

The warranty does not cover replacement or repair necessitated by loss or damage from any cause beyond the control of Comtech EF Data Corporation.

The warranty does not cover any labor involved in the removal and or reinstallation of warranted equipment or parts on site, or any labor required to diagnose the necessity for repair or replacement.

The warranty excludes any responsibility by Comtech EF Data Corporation for incidental or consequential damages arising from the use of the equipment or products, or for any inability to use them either separate from or in combination with any other equipment or products.

A fixed charge established for each product will be imposed for all equipment returned for warranty repair where Comtech EF Data Corporation cannot identify the cause of the reported failure.

Exclusive Remedies

Comtech EF Data Corporation's warranty, as stated is in lieu of all other warranties, expressed, implied, or statutory, including those of merchantability and fitness for a particular purpose. The buyer shall pass on to any purchaser, lessee, or other user of Comtech EF Data Corporation's products, the aforementioned warranty, and shall indemnify and hold harmless Comtech EF Data Corporation from any claims or liability of such purchaser, lessee, or user based upon allegations that the buyer, its agents, or employees have made additional warranties or representations as to product preference or use.

The remedies provided herein are the buyer's sole and exclusive remedies. Comtech EF Data shall not be liable for any direct, indirect, special, incidental, or consequential damages, whether based on contract, tort, or any other legal theory.

Warranty Repair Return Procedure

Before a warranty repair can be accomplished, a Repair Authorization must be received. It is at this time that Comtech EF Data will authorize the product or part to be returned to the Comtech EF Data facility or if field repair will be accomplished. The Repair Authorization may be requested in writing or by calling:

Comtech EF Data Corporation

2114 W 7th Street.
Tempe, Arizona 85281 (USA)
ATTN: Customer Support
Phone: (480) 333-2200
Fax: (480) 333-2540

Any product returned to Comtech EF Data for examination must be sent prepaid via the means of transportation indicated as acceptable to Comtech EF Data. Return Authorization Number must be clearly marked on the shipping label. Returned products or parts should be carefully packaged in the original container, if possible, and unless otherwise indicated, shipped to the above address.

Non-Warranty Repair

When a product is returned for any reason, Customer and its shipping agency shall be responsible for all damage resulting from improper packing and handling, and for loss in transit, notwithstanding any defect or nonconformity in the product. By returning a product, the owner grants Comtech EF Data permission to open and disassemble the product as required for evaluation. In all cases, Comtech EF Data has sole responsibility for determining the cause and nature of failure, and Comtech EF Data's determination with regard thereto shall be final.

Preface

P

This manual provides installation and operation information for the Radyne RCS20 M:N Redundancy Switch. This is a technical document intended for use by engineers, technicians, and operators responsible for the operation and maintenance of the RCS20.

Conventions

Whenever the information within this manual instructs the operator to press a pushbutton switch or keypad key on the Front Panel, the pushbutton or key label will be shown in "less than" (<) and "greater than" (>) brackets. For example, the Reset Alarms Pushbutton will be shown as <RESET ALARMS>, while a command that calls for the entry of a '7' followed by 'ENTER' Key will be represented as <7,ENTER>.

Cautions and Warnings



A caution icon indicates a hazardous situation that if not avoided, may result in minor or moderate injury. Caution may also be used to indicate other unsafe practices or risks of property damage.



A warning icon indicates a potentially hazardous situation that if not avoided, could result in death or serious injury.



A note icon identifies information for the proper operation of your equipment, including helpful hints, shortcuts, or important reminders.

Trademarks

Product names mentioned in this manual may be trademarks or registered trademarks of their respective companies and are hereby acknowledged.

Copyright

©2008, Comtech EF Data This manual is proprietary to Comtech EF Data and is intended for the exclusive use of Comtech EF Data's customers. No part of this document may in whole or in part, be copied, reproduced, distributed, translated or reduced to any electronic or magnetic storage medium without the express written consent of a duly authorized officer of Comtech EF Data

Disclaimer

This manual has been thoroughly reviewed for accuracy. All statements, technical information, and recommendations contained herein and in any guides or related documents are believed reliable, but the accuracy and completeness thereof are not guaranteed or warranted, and they are not intended to be, nor should they be understood to be, representations or warranties concerning the products described. Comtech EF Data assumes no responsibility for use of any circuitry other than the circuitry employed in Comtech EF Data systems and equipment. Furthermore, since Comtech EF Data is constantly improving its products, reserves the right to make changes in the specifications of products, or in this manual at any time without notice and without obligation to notify any person of such changes.

Record of Revisions

Revision Level	Date	Reason for Change
1.0	6-16-00	New Release.
2.0	4-19-01	Revised and reformatted manual.
3.0	5-4-01	Revised User Interfaces Section.
3.1	6-4-01	Revised Electrical Interfaces Section.
3.2	10-9-01	Revised the Detailed Command Descriptions Section.
3.3	12-11-01	Revised Electrical Interfaces Section.
3.4	1-8-02	Added MIB.
4.0	3-27-03	Revised and Reformatted Technical Manual.
4.1	12-18-06	Revised and Reformatted Technical Manual

Comments or Suggestions Concerning this Manual

Comments or suggestions regarding the content and design of this manual are appreciated. To submit comments, please contact the Comtech EF Data Corporation Customer Service Department.

Table of Contents

Warranty Policy	iii
Preface	v
Conventions	v
Cautions and Warnings	v
Trademarks	v
Copyright	vi
Record of Revisions	vi
Comments or Suggestions Concerning this Manual	vi
Section 1 - Introduction	1-1
1.0 Description	1-1
Section 2 - Installation	2-1
2.1 Unpacking	2-1
2.2 Removal and Assembly	2-2
2.3 Mounting Considerations	2-2
2.4 Modem Checkout	2-2
2.4.1 Initial Power-Up	2-3
Section 3 - Theory of Operation	3-1
3.0 Theory of Operation	3-1
3.1 Signal Flow	3-1
3.1.1 Interfaces	3-1
3.1.2 Data Mux	3-2
3.1.3 RF Modulators	3-3
3.1.4 RF Demodulators	3-3
3.1.5 Diversity (Option)	3-3
3.2 Start-Up Procedures	3-3
3.2.1 Initial Start-up Procedure	3-3

3.2.2 Sample Setups_____	3-4
3.2.2.1 Transmitting G.703 T3 From Interface Slot 3 (other interfaces disabled) ____	3-4
3.2.2.2 Transmitting STM-1 From Interface Slot 1 (other interfaces disabled) _____	3-4
3.2.3 Hardware Reset_____	3-4
3.3 Calculating 3 dB Bandwidth of MM200 Modulated Carrier _____	3-5
3.4 Input Level _____	3-5
Section 4 - User Interfaces	4-1
4.0 User Interfaces _____	4-1
4.1 Front Panel User Interface _____	4-1
4.1.1 Front Panel LCD Display _____	4-2
4.1.2 Cursor Control Arrows _____	4-2
4.1.3 Front Panel Keypad _____	4-2
4.1.4 Front Panel LED Indicators _____	4-3
4.1.5 Parameter Setup _____	4-3
4.2 Front Panel Control Screen Menus_____	4-4
4.3 Level 2 Menu Screens _____	4-4
4.3.1 Main Menu Screens _____	4-4
4.3.2 MODULATOR (menu) _____	4-5
4.3.3 DEMODULATOR (menu)_____	4-6
4.3.4 REPEATER (Menu) _____	4-8
4.3.4 APC (Menu) _____	4-8
4.3.5 TX INTERFACE (Menu)_____	4-9
4.3.6 RX INTERFACE (Menu) _____	4-10
4.4 All Level Menu Screens _____	4-12
4.4.1 Main Menu Screens _____	4-12
4.4.2 MODULATOR (menu) _____	4-12
4.4.3 DEMODULATOR (menu)_____	4-13
4.4.4 REPEATER (menu) _____	4-17
4.3.4 APC (Menu) _____	4-17
4.4.5 TX INTERFACE (Menu)_____	4-17
4.4.6 RX INTERFACE (Menu) _____	4-20
4.4.7 MONITOR (Menu) _____	4-21
4.4.8 ALARMS (Menu) _____	4-24
4.4.8.1 Active Alarms _____	4-24

4.4.8.2 Latched Alarms _____	4-28
4.4.8.3 Clear Alarms _____	4-28
4.4.9 SYSTEM (Menu) _____	4-28
4.4.10 TEST (Menu) _____	4-30
4.5 Remote Port User Interface _____	4-30
4.5.1 Protocol Structure _____	4-31
4.5.2 Protocol Wrapper _____	4-31
4.5.3 Frame Description and Bus Handshaking _____	4-33
4.5.4 Global Response Operational Codes _____	4-34
4.5.5 Collision Avoidance _____	4-36
4.5.6 Software Compatibility _____	4-37
4.5.7 RLLP Summary _____	4-38
4.6 Simple Network Management Protocol (SNMP) _____	4-38
4.7 The Management Information Base (MIB) _____	4-38
4.8 Directory _____	4-38
4.9 Mgmt _____	4-39
4.10 Experimental _____	4-39
4.11 Private _____	4-39
4.12 Terminal Port User Interface _____	4-40
4.13 Modem Configuration _____	4-40
4.14 Connecting the Terminal _____	4-40
4.15 SNMP Option _____	4-42
4.16 Network Configuration _____	4-42
4.17 Terminal Screens _____	4-42
4.18 Logging on and Passwords _____	4-43
4.19 Exiting SNMP Configuration _____	4-44
4.20 Logging On _____	4-44
4.21 Changing the Logon Password _____	4-44
4.22 Logging Off _____	4-45
4.23 Changing Your Authentication Password _____	4-45
4.24 Changing Your Privacy Password _____	4-45
4.25 Modem MM200 High-Speed Microwave Modem Ethernet Address _____	4-46
4.26 Modem IP Address _____	4-46
4.27 Server Ethernet Address _____	4-46
4.28 Server IP Address _____	4-46

4.29	Server Host Name _____	4-46
4.30	Router IP Address _____	4-47
4.31	IP Address Mask _____	4-47
4.32	Boot Mode (Optional) _____	4-47
4.33	Community _____	4-47
4.34	Trap Type and Trap Hosts _____	4-47
4.35	Trace Mode _____	4-48
4.36	SNMP V1 & 2 Access View _____	4-48
4.37	Key Generation Mode _____	4-48
4.38	Context Engine ID _____	4-48
4.41	Connect the Ethernet Cable _____	4-49
4.42	Ping Program _____	4-50
4.43	SNMP Test _____	4-51
Section 5 - Electrical Interfaces		5-1
5.0	MM200 Connections _____	5-1
5.1	Power _____	5-1
5.1.1	AC Power _____	5-1
5.1.2	DC Power _____	5-1
5.2	Alarm Port _____	5-2
5.3	Terminal Port (I/O) _____	5-3
5.4	Remote Port (I/O) _____	5-3
5.4.1	Remote Port Cabling for a Standard Computer RS-232 COM Port _____	5-4
5.5	Ethernet Interface (I/O) _____	5-5
5.6	TX RF Port (Output) _____	5-5
5.7	RX RF Port (Input) _____	5-5
5.8	External Reference (Input) _____	5-5
5.9	Interface Slots 1 Through 4 _____	5-6
5.10	High-Speed G.703/DS3, E3, STS-1 Rear Panel Interface _____	5-6
5.10.1	G.703 OUT Female BNC Connector (J15) _____	5-6
5.10.2	CLK IN Female BNC Connector (J16) _____	5-6
5.10.3	G.703 IN Female BNC Connector (J17) _____	5-6
5.11	Overhead/DS0 Audio Rear Panel Interface _____	5-7
5.11.1	DS01 15-Pin Female HD 'D' Sub Connector (J7) _____	5-8
5.11.2	DS02 15-pin female HD 'D' sub connector (J8) _____	5-8

5.11.3 DS03 15-pin female HD 'D' sub connector (J9)	5-8
5.11.4 DS04 15-pin female HD 'D' sub connector (J10)	5-8
5.11.5 DS05 15-pin female HD 'D' sub connector (J11)	5-8
5.11.6 DS06 15-pin female HD 'D' sub connector (J12)	5-8
5.11.7 DS07 15-pin female HD 'D' sub connector (J13)	5-9
5.11.8 DS08 15-pin female HD 'D' sub connector (J14)	5-9
5.12 Optical/OC3 STM-1 Rear Panel Interface	5-9
5.12.1 ELEC OUT Female BNC Connector (J15)	5-9
5.12.2 ELEC IN Female BNC Connector (J16)	5-9
5.12.3 OPTICAL IN SC Connector (J17)	5-9
5.12.4 Optical Out SC Connector (J18)	5-9
5.12.5 REF OUT Female BNC Connector (Optional) (J19)	5-9
5.12.6 REF IN Female BNC Connector (Optional) (J20)	5-9
5.13 ASI Rear Panel Interface	5-10
5.13.1 ASI OUT Female BNC Connector (J15)	5-10
5.13.2 ASI IN Female BNC Connector (J16)	5-10
5.14 Wayside G.703/T1, E1 Rear Panel Interface	5-10
5.14.1 IN Female BNC Connector (J15)	5-10
5.14.2 OUT Female BNC Connector (J16)	5-11
5.14.3 BALANCED 15-pin female 'D' sub connector	5-11
5.14.4 CLK OUT (J17)	5-11
5.14.5 CLK IN Female BNC Connector (J18)	5-11
5.15 Parallel RS-422/DVB, M2P	5-11
5.15.1 PARALLEL TX 25-pin female 'D' sub connector (J15)	5-12
5.15.2 PARALLEL RX 25-pin female 'D' sub connector (J16)	5-13
5.15.3 CLK IN (J17)	5-13
5.15.4 CLK IN Female BNC Connector (J18)	5-13
5.16 Parallel LVDS/DVB, M2P	5-14
5.16.1 PARALLEL TX 25-pin female 'D' sub connector (J15)	5-14
5.16.2 PARALLEL RX 25-pin female 'D' sub connector (J16)	5-15
5.16.3 CLK IN (J17)	5-15
5.16.4 CLK IN Female BNC Connector (J18)	5-16
5.17 SMPTE/310M Rear Panel Interface	5-16
5.17.1 EXT CLK (J15)	5-16
5.17.2 SMPTE IN Female BNC Connector (J16)	5-16

Section 6 - Maintenance and Troubleshooting	6-2
6.0 Periodic Maintenance	6-2
6.1 Maintenance Philosophy	6-2
6.2 Customer Service	6-2
6.3 Troubleshooting	6-3
Section 7 - Technical Specifications	7-1
7.0 Introduction	7-1
7.1 Specifications	7-1
7.2 Options	7-1
7.3 Optional Data Interfaces	7-2
7.4 Optional Overhead Interfaces	7-2
Appendix A - Remote RLLP	A-1
A.1 MM200 Opcode Command Set	A-1
A.2 Modem Command Set	A-1
A.3 Detailed Command Descriptions	A-4
Appendix B - SNMP MIB	B-1
Glossary.....	G-1

Introduction

1

1.0 Description

The Radyne MM200 Microwave Modem is a high-speed, multi data rate Modulator/Demodulator. It is a single rack digital modem for point-to-point or point-to-multipoint communication links and is ideal for microwave link upgrades or retrofits.

The MM200 utilizes a proprietary matrix modulation format that provides maximum bandwidth efficiency and data rates up to 176 Mbps (200 Mbps optional). Increased performance is achieved in multi-path or fading environments over conventional QAM modulation.

The MM200 offers a large variety of interfaces such as T3, E3, STS1, DVB SPI, DVB ASI, OC3/STM-1, T1, E1, E2, 10Base T, and others.



Figure 1-1. MM200 Microwave Modem



Installation

2

2.0 Installation Requirements

The MM200 is designed to be installed within any standard 19-inch equipment cabinet or rack, and requires 2 rack unit (RU) mounting spaces (3.5 inches) vertically and 19 inches of depth. Including cabling, a minimum of 20 inches of rack depth is required. The rear panel of the MM200 is designed to have power enter from the left and IF cabling enter from the right when viewed from the rear of the unit. Data and control cabling can enter from either side although they are closer to the center. The unit can be placed on a table or suitable surface if required.

WARNING!!

There are no user-serviceable parts or configuration settings located inside the MM200 chassis. There is a potential shock hazard internally at the power supply module. DO NOT open the MM200 chassis under any circumstances.

CAUTION!!

Before initially applying power to the unit, it is a good idea to disconnect the transmit output from the operating station equipment. This is especially true if the current MM200 configuration settings are unknown, where incorrect setting could disrupt existing communications traffic.

*The MM200 contains a Lithium Battery. **DANGER OF EXPLOSION** exists if the battery is incorrectly replaced. Replace only with the same or equivalent type recommended by the manufacturer. Dispose of used batteries in accordance with manufacturers instructions*

2.1 Unpacking

The MM200 Modem was carefully packaged to avoid damage and should arrive complete with the following items for proper installation:

- MM200 Unit
- Prime power connection
- Installation and Operation Manual

2.2 Removal and Assembly

If using a knife or cutting blade to open the carton, exercise caution to ensure that the blade does not extend into the carton, but only cuts the tape holding the carton closed. Carefully unpack the unit and ensure that all of the above items are in the carton. If the Primary AC power available at the installation site requires a different power cord/AC connector, then arrangements to receive the proper device will be necessary before proceeding with the installation.

The MM200 modem is shipped fully assembled and does not require removal of the covers for any purpose in installation. Should the power cable AC connector be of the wrong type for the installation, either the cable or the power connector end should be replaced. The power supply itself is designed for universal application using from 100 to 240 VAC, 50-60 Hz, 1A or 37 – 75 VDC @ 4A.

2.3 Mounting Considerations

When mounted in an equipment rack, adequate ventilation must be provided. The MM200 draws air in from the left hand side and exhausts from the right rear and side (as viewed from the front). Do not install the unit in closed locations where this airflow will be restricted. The exhaust air must be allowed to vent away from the unit and not be allowed to flow back into the air input. The ambient temperature in the rack should be between 0° and 50° C, and held constant for best equipment operation. The air available to the rack should be clean and relatively dry

Do not mount the MM200 in an unprotected outdoor location where there is direct contact with rain, snow, wind or sun. The MM200 is designed for indoor applications only.

The only tools required for rack mounting the MM200 is a set of four rack mounting screws and an appropriate screwdriver. Rack mount brackets are an integral part of the cast front bezel of the unit and are not removable.

Shielded cables with the shield terminated to the conductive backshells are required in order to meet EMC directives. Cables with insulation flammability ratings of 94 VO or better are required in order to meet low voltage directives.

2.4 Modem Checkout

The following descriptions assume that the MM200 is installed in a suitable location with prime power and supporting equipment available.

2.4.1 Initial Power-Up



Before initial power up of the MM200, it is a good idea to disconnect the transmit output from the operating ground station equipment. This is especially true if the current modem configuration settings are unknown, where incorrect setting could disrupt existing communications traffic. New units from the factory are normally shipped in a default configuration which includes setting the transmit carrier off.

Turn the unit 'ON' by applying power (DC versions), or placing the rear panel switch (above the power entry connector) to the 'ON' position (AC versions). Upon initial and subsequent power-ups, the MM200 microprocessor will test itself and several of its components before beginning its main monitor/control program. These power-up diagnostics show no results if successful.



Theory of Operation

3

3.0 Theory of Operation

The MM200 Microwave Modem is a highly flexible platform for the transmission of high-speed data across links such as microwave and cable. The 2 RU-rack mount unit can be supplied in many different configurations and was designed to be expanded in the field to meet new and changing operating conditions. Available in Duplex and Simplex Configurations, the unit can be optioned with up to four industry standard interfaces in any combination, Diversity (requires two chassis), maximum rates of 50, 100, 150, 175, and 200 Mbps, and world standard AC or DC prime power.

The fully configured MM200 includes a data multiplexer/demultiplexer for interfacing to multiple data sources, a modulator, and a demodulator. The MM200 is capable of data rates up to 200 Mbps at any of six different Quadrature Amplitude Modulation (QAM) schemes including QAM256 (optional). The unique modulation/demodulation scheme uses multiple carriers to slow the modulated symbol rate to up to four times slower than conventional modems. The lower symbol rate is inherently more resilient to the multipath environment common to microwave systems. An extremely powerful equalizer, working at the lower symbol rate, removes multipath and is coupled with Reed Solomon Noise Reduction System to form a robust, reliable communications link. Additionally, two receivers can be optioned with diversity cards. The two chassis are then coupled via a high-speed data link to allow the automatic hitless switching to the receiver with no errors. This feature can be used for standard path redundancy on long links or to improve the capacity (via an increase in modulation mode) of an existing link. Refer to Figure 3-1 for operational block diagram.

3.1 Signal Flow

3.1.1 Interfaces

The transmit customer data interface consists of four “slots”. Each slot can accept one of a range of industry standard interface cards including:

- DVB ASI (1 to 160 Mbps)
- DVB SPI (1 to 160 Mbps)
- G.703 E3/DS3/STS-1
- G.703 T1/E1
- G.703 E2
- OC3/STM-1 optical/electrical
- Orderwire, 8 synchronous, 64 Kbps, RS-422 (one channel can be switched to ADPCM)
- 10Base T Ethernet

Data between interface slots can be Asynchronous and in any combination. Careful attention to the maximum data rate and its relationship to bandwidth are required for the correct operating conditions.

Some Interface Cards are capable of multiple standards such as the DS3,E3 or STS-1. These cards can operate in any one of the standards listed. Changing to another standard simply requires a change in the front panel configuration.

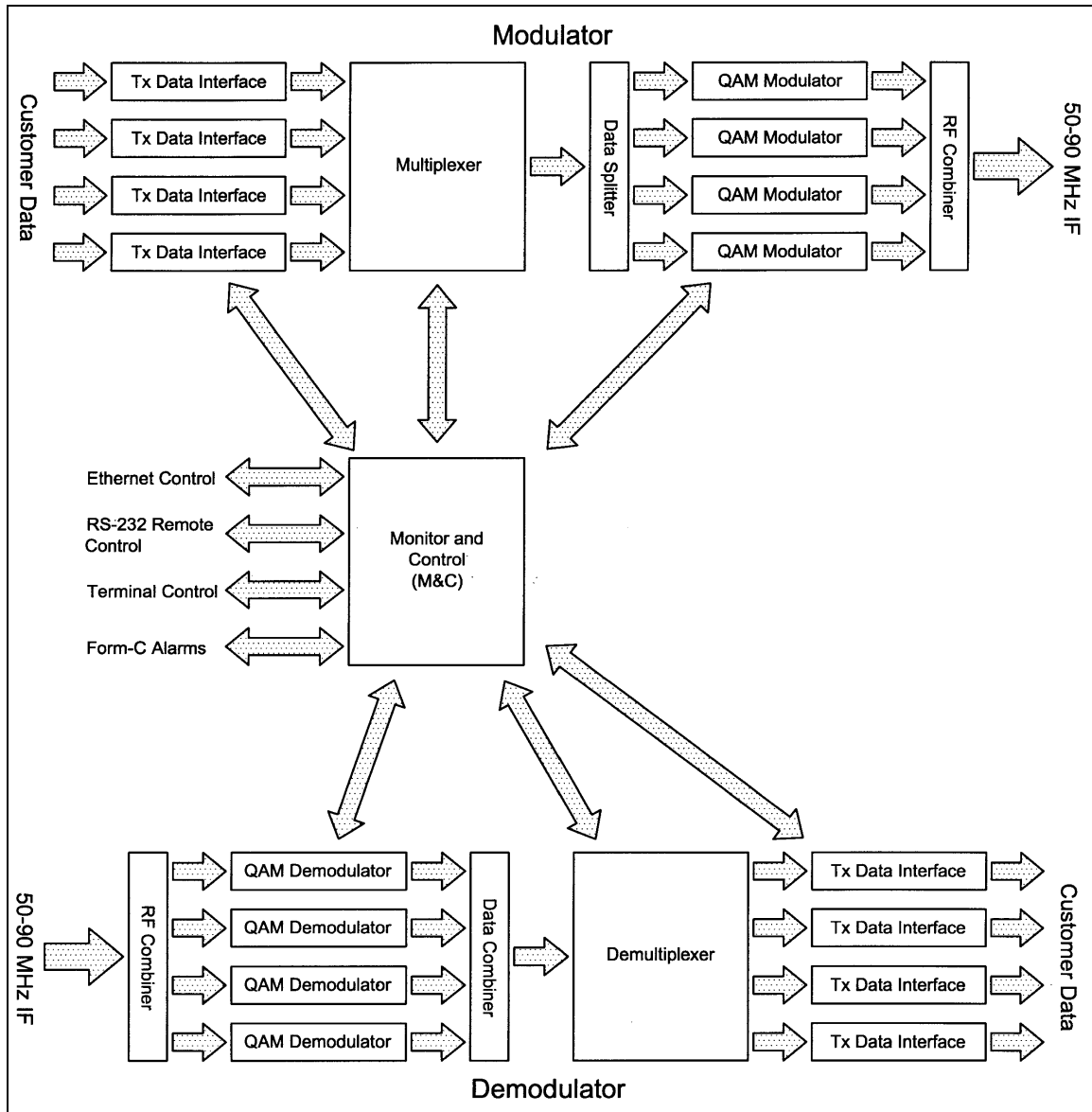

Figure 3-1. MM200 Microwave Modem Block Diagram

3.1.2 Data Muxiplexer

The multiplexer works on a constant output data rate. This data rate is directly related to the symbol rate used by the modulators. The Symbol Rate is directly related to Bandwidth of the IF carrier. The output of the multiplexer contains Reed Solomon overhead and mux/demux overhead. The ratio between multiplexer input data and output data is 184/204. To accommodate changes in the data rate supplied by the customer and the constant output of the mux, the gaps are filled with null data that is later removed by the demux. Therefore, the customer data is completely variable up to the point where the mux overflows. Variable interfaces like the DVB ASI can take full advantage of this feature.

The single stream output of the mux is sent to a digital splitter that can have between one and four outputs, which corresponds to the number of RF modulators installed.

Data is always evenly divided between the number of channels selected i.e. each RF modulator runs at the same rate.

3.1.3 RF Modulators

The number of active modulators (up to the maximum number installed in the chassis, from 1 to 4) is determined by front panel selection in which case any unused modulator is “parked” or turned off. Each modulator is capable of modulating a carrier between 50 and 90 MHz with QAM 4,16,32,64,128 or 256 (optional). The range of symbol rates per modulator is 3.5 to 7 Msps giving a total range of 3.5 to 28 Msps. The four outputs are combined to a single IF output. Output power is adjusted by a 1 dB step attenuator.

3.1.4 RF Demodulators

The RF Demodulators mirror the RF Modulators in their specifications. The receive signal is split four ways each going to an independent demodulator. Again, the number of demodulators (up to the maximum number installed in the chassis, from 1 to 4) can be set from the front panel. The Modulator and Demodulator setup must be identical for the signal to pass.

Each demodulator has a powerful digital equalizer to remove multipath and other signal degradations.

The Demux removes the overhead and sends the appropriate data to the appropriate interface as identified by its unique PID (Packet Identifier). The Tx interface must match the Rx interface.

3.1.5 Diversity (Option)

When the system requires Diversity such as Space Diversity or Frequency Diversity, the receiving site must have two independent receive signals. Each of the two MM200 chassis are required to be optioned with a minimum of identical receivers (number of RF channels) and a diversity card. Only one chassis needs to be optioned with interfaces if no equipment redundancy is required. The transmit side of both chassis are completely independent from diversity operation and can therefore be optioned in any configuration.

Data from the demux is sent to the diversity card where it is buffered and aligned in time with the signal received from the other diversity card. Both these signals appear at the hitless switch. Error information from all receivers is sent to the hitless switch driver where a decision is made as to which stream to output. The output will be error-free providing one of the demodulator chassis is receiving an error-free signal. If both chassis are receiving errored signals, the output can still be error-free providing errors occur in different Reed-Solomon packets.

Both diversity cards send and receive data to and from the other unit, so both chassis will output the best data stream of the two units.

3.2 Start-Up Procedures

3.2.1 Initial Start-up Procedure

1. Turn the unit on.
2. Set Tx Power to ‘-10 dBm’.
3. Set the Demodulator Attenuation to ‘20 dB’.
4. Under the Mod/Demod Test, set PRBS to ‘-2e23M’.
5. Connect IF Out to IF In via a 75Ω Coax Cable.

6. Modem should lock with SNRs > 32 dB.

3.2.2 Sample Setups

3.2.2.1 Transmitting G.703 T3 From Interface Slot 3 (other interfaces disabled) Sample Setup

1. In System, User Mode, set to 'Level 2'.
2. In Modulator, set the frequency to '70 MHz'.
3. In Tx Interface 3, set Control to 'Enable' (ensure all other interfaces are disabled).
4. Set Interface to 'T3'.
5. Set Data Inv to 'Norm'.
6. Set Bandwidth in the Modulator Menu to '30,000,000'.
7. Set the Demodulator to a frequency of '70 MHz'.
8. In Rx Interface 3, set Control to 'Enable' (ensure all other interfaces are disabled).
9. Set Interface to 'T3'.
10. Set Data Inv to 'Norm'.
11. Set the bandwidth in the Demodulator Menu to '30,000,000'.

3.2.2.2 Transmitting STM-1 From Interface Slot 1 (other interfaces disabled) Sample Setup

1. In System, User Mode, set to 'Level 2'.
2. In Modulator, set the frequency to '70 MHz'.
3. In Tx Interface 1, set Control to 'Enable' (ensure all other interfaces are disabled).
4. Set Interface to 'STM-1'.
5. Set Data Inv to 'Norm'.
6. Set the bandwidth in the Modulator Menu to '30,000,000'.
7. Set the Demodulator to a frequency of 70 MHz.
8. In Rx Interface 1, set Control to 'Enable' (ensure all other interfaces are disabled).
9. Set Interface to 'STM-1'.
10. Set Data Inv to 'Norm'.
11. Set the Bandwidth in the Demodulator Menu to '30,000,000'.

3.2.3 Hardware Reset

This section is not yet complete.

3.3 Calculating 3dB Bandwidth of MM200 Modulated Carrier

1. Find the combined interface data rate:

$$DR_C = \text{Interface 1 Data Rate} + \text{Interface 2 Data Rate} + \text{Interface 3 Data Rate} + \text{Interface 4 Data Rate}$$

2. Find the Total Data Rate plus R/S mux overhead, and guard band overhead:

$$DR_T = DR_C \times (204/184) \times 1.001$$

3. Find Channel Baud Rate:

$$BR_C = DR_T / (QAM \times N_C)$$

Where N_C = number of channels (one to four)

and QAM = 2 for 4 QAM

4 for 16 QAM

5 for 32 QAM

6 for 64 QAM

7 for 128 QAM

8 for 256 QAM

4. Select Channel Spacing:

C_S = from 1.1 to 1.5 times channel baud rate.

This number is usually 1.25 but may be set anywhere within the range of 1.1 to 1.5.

5. Total 3 dB bandwidth = $BR_C \times C_S \times (N_C - 1) + BR_C$

3.4 Input Level

Each IF channel has an independent dynamic range of 15 - 20 dB. This allows greater performance during frequency selective fades. For normal operation, the MM200 was designed to work with radios that have automatic gain control (AGC). The radio AGC will generally use the average power of all the IF channels to set its power unlike the MM200 that independently AGCs on each IF channel. When setting up the input level to the MM200, use the following procedure.

1. If the Radio has a IF output level setting, adjust to the manufactures optimum point. If there is none, set between 0 and -10 dBm.
2. Verify that the input to the radio is not experiencing frequency selective fading or a deep flat fade.
3. Set the MM200 Demodulator attenuator (in the Demod menu) so that the AGC level display reads approximately 340 (in the Monitor, Demodulator Menu). When multiple IF channels exist there will be differences in AGC from channel to channel. These should only be of concern if any channel exceeds 300 or is lower than 400. The AGC display displays the value the M&C has assigned to the channel.

This display is un-calibrated and has a useful range of approximately 300 to 655. The number is inversely proportional to the incoming signal (a higher number indicates a lower incoming signal).



User Interfaces

4

4.0 User Interfaces

There are four user interfaces available for the MM200. These are:

- Front Panel Control.
- Command Interface Control.
- Terminal Interface
- Ethernet SNMP

Any of these methods may be used separately or together to monitor and control the MM200. Each of these interfaces and their respective methods are discussed separately below.

4.1 Front Panel User Interface

The front panel of the MM200 allows for complete monitor and control (M&C) of all parameters and functions via a keypad, LCD display and status LEDs.

The front panel layout is shown in Figure 4–1, showing the location and labeling of the front panel. The front panel is divided into four functional areas: the Front Panel LCD Display, the Cursor Control Arrows, the Numeric Keypad, and the Front Panel LED Indicators, each described below in Table 4-1.

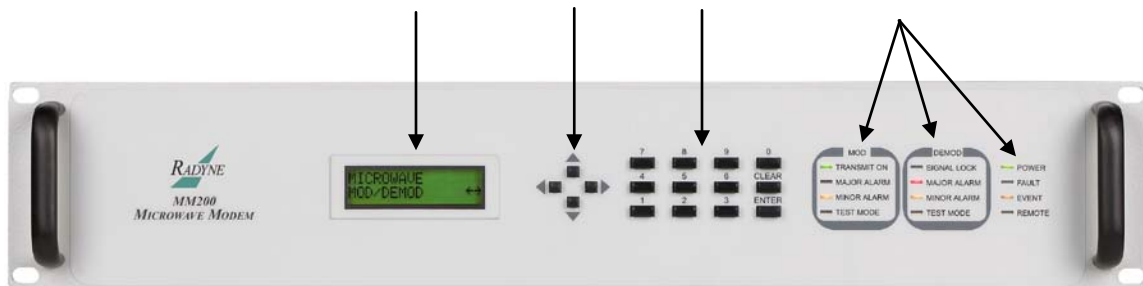

Figure 4-1. MM200 Front Panel Controls and Indicators

Table 4-1		
Item No.	Description	Function
1	Front Panel LCD Display	Displays MM200 Operating parameters and Configuration data.
2	Cursor Control Arrows	Controls the up, down, left, and right movement of the cursor in the Front Panel LCD Display.
3	Numeric Keypad	Allows entry of numeric data, and the Clear and Enter function keys.
4	Front Panel LED Indicators	Refer to Section 4.1.2 for an itemized description of these LEDs.

4.1.1 Front Panel LCD Display

The front panel display is a 2 line by 16-character LCD display. The display is lighted and the brightness can be set to increase when the front panel is currently in use. The LCD display automatically dims after a period of inactivity. The display has two distinct areas showing current information. The upper area shows the current parameter being monitored, such as 'Frequency' or 'Data Rate'. The lower line shows the current value of that parameter. The LCD display is a single entry window into the large matrix of parameters that can be monitored and set from the front panel.

4.1.2 Cursor Control Arrows

The 'Cursor' or 'Arrow' Keys (↑), (↓), (→), (←), are used to navigate the parameter currently being monitored or controlled. Table 4-2 describes the key functions available at the front panel.

Table 4-2.							
Edit Mode Key Functions (Front Panel Only)							
Parameter Type	0 – 9	↑	↓	←	→	'Clear' & ←	'Clear' & →
Fixed Point Decimal	Changes Digit	Toggles ± (If Signed)	Toggles ± (If Signed)	Moves Cursor 1 Position Left	Moves Cursor 1 Position Right	N/A	N/A
Unsigned Hexadecimal	Changes Digit	Increments Digit Value	Decrements Digit Value	Moves Cursor 1 Position Left	Moves Cursor 1 Position Right	N/A	N/A
Enumerated	N/A	Previous Value in List	Next Value in List	N/A	N/A	N/A	N/A
Date/ Time	Changes Digit	N/A	N/A	Moves Cursor 1 Position Left	Moves Cursor 1 Position Right	N/A	N/A
IP Address	Changes Digit	Increments Digit Value	Decrements Digit Value	Moves Cursor 1 Position Left	Moves Cursor 1 Position Right	N/A	N/A
Text Strings	Changes Character	Increments Character Value	Decrements Character Value	Moves Cursor 1 Position Left	Moves Cursor 1 Position Right	Clears to Left of Cursor Inclusive	Clears to Right of Cursor Inclusive

4.1.3 Front Panel Keypad

The Front Panel Keypad consists of a 10-key numeric entry with two additional keys for the 'Enter' and 'Clear' functions. Table 4-2 describes the key functions available at the front panel.

4.1.4 Front Panel LED Indicators

There are 12 LEDs on the MM200 front panel to indicate the status of the MM200's operation (refer to Table 4-3). The LED colors maintain a consistent meaning. Green signifies that the indication is appropriate for normal operation, Yellow means that there is a condition not proper for normal operation, and Red indicates a fault condition that will result in lost communications.

Table 4-3		
LED	Color	Function
Transmit On	Green	Indicates the MM200 Transmitter is turned on.
Major Alarm	Red	Indicates that the transmit direction has failed, losing traffic.
Minor Alarm	Yellow	Indicates a transmit warning condition exists.
Test Mode	Yellow	Indicates the modulator is involved in a current test mode activity.
Signal Lock	Green	Indicates the modem has received a signal and is locked
Major Alarm	Red	Receive direction failed.
Minor Alarm	Yellow	Receive learning condition.
Test Mode	Yellow	Indicates the modem is involved in a current test mode activity.
Power	Green	Indicates the MM200 unit is currently powered-up.
Fault	Red	Indicates a general equipment fault.
Event	Yellow	Indicates that a new event has been logged into the Event Buffer.
Remote	Green	Indicates that the unit is set to respond to the remote control or terminal input.

4.1.5 Parameter Setup

Use the four arrow keys, to navigate the menu tree and select the parameter to be set. After arriving at a parameter that needs to be modified, depress <ENTER>. The first space of the modifiable parameter highlights (blinks) and is ready for a new parameter to be entered. After entering the new parameter using the keypad, depress <ENTER> to lock in the new parameter. If a change needs to be made prior to pressing <ENTER>, depress <CLEAR> and the display defaults back to the original parameter. Depress <ENTER> again and re-enter the new parameters followed by <ENTER>.

Following a valid input, the MM200 will place the new setting into the nonvolatile EEPROM making it available immediately and available the next time the unit is powered-up.

4.2 Front Panel Control Screen Menus

The Front Panel Control Screen Menus are listed below. The MM200 Microwave Modem may be operated in three different levels:

Level 0 - is for specialized factory configurations. Every screen is available including those used for factory calibration and diagnostics.

Level 1 – includes those screens necessary for field maintenance.

Level 2 – is the default setting and is shipped from the factory in this mode. The screens are available that provide the quickest form of setup and use.

Note: *Screens Menus are listed below by level (L0, L1, and L2) and may be Read/Write (RW) or Read Only (RO).*

4.3 Level 2 Menu Screens

Level 2 menus screens allow for the quickest operation and system setup.

4.3.1 Main Menu Screens

Main Menu Screens (one of which is a Title Screen) are listed below:

MM-200 MODULATOR

Title Screen:

Not a modifiable screen.

MODULATOR (menu):

DEMODULATOR (menu):

REPEATER (menu):

APC (menu):

TX INTERFACE (menu):

RX INTERFACE (menu):

MONITOR (menu):

ALARMS (menu):

SYSTEM (menu):

TEST (menu):

4.3.2 MODULATOR (menu) *

The Modulator Menu Screens are listed below:

Screen Name	Selections and Descriptions	L2
FREQUENCY (Hz)	{50 – 90 MHz} Controls the current center band of the operating frequency width, or the individual channel frequency if the System Frequency Control is set to 'User'.	RW
CHANNELS	{Auto, 1 - 4} Controls the number of channel cards where 0 = auto, and 1 – 4 = the number of cards. Increase this number for better performance. Lower this number for better bandwidth efficiency.	RW
SYMB RATE (SPS)	{3.5 – 28 Msps} Controls the total Symbol Rate.	RO
MODULATION	{QAM4, QAM16, QAM32, QAM64, QAM128, QAM256} Displays the current Modulation Scheme. Performance is increased by using the lowest QAM Mode possible for the required bandwidth.	RO
BANDWIDTH (Hz)	Enters the 3 dB bandwidth of the modulated IF Output. When the radio must meet a particular spectral mask, set this number to something below the masks 3 dB points (i.e. 5% less). For best performance, do not allow the MM200s bandwidth to be greater than the radios 1 dB bandwidth.	RW
UTILIZATION (%) *	Displays the percentage of the data being transferred that is being used by the selected interfaces. Must be less than 100% (Maximize this number for best bandwidth efficiency by lowering the symbol rate, QAM Mode, or the number of channels).	RO
MAX PAYLOAD (Hz)	Displays the maximum total data rate that is useable for the current settings.	RO
SPECTRUM	{Normal, Inverted} Used for inverting the spectrum. If the unit cannot lock to the signal after passing through the radio, try these settings.	RW
TX POWER	{0 to –25 dBm} Sets the IF Output Power in 1 dB steps.	RW
TX ENABLE	{Off, On} Forces the Carrier to Off or On.	RW

4.3.3 DEMODULATOR (menu)

The Demodulator Menu Screens are listed below:

Screen Name	Selections and Descriptions	L2
FREQUENCY (Hz)	{50 – 90 MHz} Displays the current center band of the operating frequency width.	RW
CHANNELS	{Auto, 1 – 4, Debug} Controls the number of channel cards where 0 = auto, and 1 – 4 = the number of cards. Increase this number for better performance. Lower this number for better bandwidth efficiency.	RW
SYMB RATE (SPS)	{3.5 – 28 Msps} Controls the total Symbol Rate.	RO
DEMODULATION	{QAM4, QAM16, QAM32, QAM64, QAM128, QAM256} Displays the current Demodulation Scheme.	RO
BANDWIDTH (Hz)	Displays the frequency difference between the highest channel's upper 3-dB point and the lowest channel's lower 3-dB point.	RW
UTILIZATION (%)	Displays the percentage of the data being transferred that is being used by the selected interfaces. Must be less than 100%. Maximize this number for best bandwidth efficiency by lowering the symbol rate, QAM Mode, or the number of channels.	RO
MAX PAYLOAD (Hz)	Displays the maximum total data rate that is useable for the current settings.	RO
SPECTRUM	{Normal, Inverted}	RW
ATTENUATION	{0 - 31} Sets the Demodulator Input IF Attenuator in 1 dB steps.	RW
ACQUISITION (menu):	<p>The Demodulator Acquisition Frequency range can be set by the user. This is required at higher QAM rates when using radios with significant frequency drift. As QAM rates increase, the ability of the receiver to acquire to a signal that is offset from the programmed demodulator frequency is reduced. At QAM256 the acquisition window can be as low as ± 50 kHz. Yet at QAM4, the window can be over ± 1 MHz. This range can be further reduced by noise or degraded receive signals.</p> <p>When trying to acquire a signal, the MM200 follows this procedure:</p> <ol style="list-style-type: none"> 1. Try to acquire at the Demodulator Programmed Frequency. 2. Continue to try to acquire for the length 	

	<p>of time set in ACQ DELAY (sec).</p> <ol style="list-style-type: none"> 3. Step the Demodulator frequency up one step size programmed in ACQ STEP (KHz). 4. Repeat Steps 1 through 3 until the Demodulator Frequency exceeds the + side of the ACQ BW. 5. Set the Demodulator to the negative side of ACQ BW. 6. Repeat until demodulator acquires. Once acquired, the demodulator will have an offset between the frequency at which the demodulator is set and the incoming signal frequency. This is due to demodulator frequency acquisition window and radio drift. This can cause degraded performance and, in the case of radio drift, possible loss of lock. To overcome this, once acquired, the demodulator reduces this offset to 0 Hz by slowly incrementing/decrementing the demodulator frequency. The speed can be adjusted by adjusting the TRACK STEP (Hz). It is suggested that this parameter normally be set to 10 Hz. 	
ACQ CONTROL	{Off, Acquire} Always set to Acquire.	RW
ACQ BW (kHz)	{50 KHz – 400 kHz} Sets the \pm acquisition bandwidth. There is a tradeoff between this number and acquisition speed.	RW
ACQ DELAY (sec)	{10 – 255 sec} Sets the time that the demodulator stays at a frequency before trying the next step.	RW
REACQ DELAY (sec)	{10 – 255 sec} Sets the time that the demodulator remains at frequency after it first loses lock.	RW
ACQ STEP (kHz)	{10 – 100 kHz} Sets the frequency step size the demodulator will take when trying to acquire.	RW
TRACKING STEP (Hz)	{10 – 100 Hz} Sets the step size that the demodulator will use to remove the frequency error of a locked signal. Normally set to 10 Hz.	RW
DIVERSITY (menu):	Diversity	
MODE	{Disable, Auto, Force A, Force B}	RW

MONITOR (menu):	Controls the diversity mode.	
	Diversity channel and FIFO status.	
MUX STATUS	{Unused, Channel A, Channel B, Null Frames} Specifies the multiplexer status.	RW
FIFO A STATUS	{No Flags, Empty, Full} Specifies the status of FIFO A.	RW
FIFO B STATUS	{No Flags, Empty, Full} Specifies the status of FIFO B.	RW
CHANNEL A ERR	Displays the Channel A error counter.	RO
CHANNEL B ERR	Displays the Channel B error counter.	RO
CHANNEL AB ERR	Displays the Channel A and B error counter.	RO

4.3.4 REPEATER (Menu)

The primary Repeater screen is listed below:

Screen Name	Selections and Descriptions	L2
MODE	{Off, On} Enables the repeater feature.	RW

4.3.4 APC (Menu)

The primary APC screen is listed below:

Screen Name	Selections and Descriptions	L2
TRANSMIT (menu):	APC Transmit settings.	
XMT CONTROL	{TXDOWN, TXUP, AUTO} Controls the local TX level.	RW
MAX TX LEVEL	Sets the maximum TX power level.	RW
MIN TX LEVEL	Shows the minimum TX power level.	RO
DEF TX LEVEL	Sets the default TX power level.	RW
STEP SIZE	Sets the TX power step size.	RW
APC RANGE	Sets the power level range.	RW
APC SPEED	Sets the TX power step speed.	RW

RECEIVE (menu):	APC Receive settings.	
RCV CONTROL	{RXDOWN, RXUP, AUTO} Controls the remote TX level.	RW
LEVEL (dBm)	Desired RX power level.	RW
HYSTERESIS	APC Hysteresis.	RW
MONITOR (menu):	APC Monitor.	
XMT STATUS	{NOCHANGE, TXDOWN, TXUP} Displays APC transmit status.	RO
RCV STATUS	{NOCHANGE, RXDOWN, RXUP} Displays APC receive status.	RO

4.3.5 TX INTERFACE (Menu)

The primary Tx Interface Screens and their sub-menus as listed below:

Screen Name	Selections and Descriptions	L2
TX INTRFC1 (menu):	Transmit Interface 1	
CONTROL	{Disable, Enable} Enables or disables the installed interface.	RW
DATA RATE (BPS)	Dependant upon interface type. For variable interfaces, this unit must be set by the user. Will not show up on fixed rate interfaces.	RW
INTERFACE	Dependant upon interface type. Selects the interface standard for multiple standard interface card, or displays standard for fixed interfaces.	RW
FRAMING	{Unframed, MPEG188, MPEG204} Used for DVB Interface framing selection. Shows only in DVB Framed Interfaces. Note: Only appears when supported by the installed interface.	RW
JIT CONTROL	{NORMAL, STAMP2, STAMP3} Normal or Time-Stamped packets.	RW
NULL PID	{2-Byte Packet ID} Defines the 2-byte packet ID, program ID for null padding packets. This number must match the corresponding receive demux null PID. This number must be unique and not be duplicated by an interface PID or any DVB transport stream	RW

	PIDs on a framed interface. Note: Only appears when using DVB Framed Interfaces such as L0I.	
CLK POLARITY	{Normal, Inverted} Sets the polarity of the clock. Note: Only appears when supported by the installed interface.	RW
DATA INVERT	{Normal, Inverted} Sets the polarity of the data. Note: Only appears when supported by the installed interface.	RW
BB LOOP	{Normal, Inverted} Baseband Loopback. Not yet implemented, for future expansion.	RW
VOLUME	{0 - 255} Allows the user to set volume level (Orderwire only). Note: Only appears when supported by the installed interface.	RW
TX INTRFC2 (menu)	Transmit Interface 2. Refer to TX INTRFC1 (menu) for descriptions.	
TX INTRFC3 (menu)	Transmit Interface 3. Refer to TX INTRFC1 (menu) for descriptions.	
TX INTRFC4 (menu)	Transmit Interface 4. Refer to TX INTRFC1 (menu) for descriptions.	

4.3.6 RX INTERFACE (Menu)

The primary Rx Interface Screens and their sub-menus as listed below:

Screen Name	Selections and Descriptions	L2
RX INTRFC1	Receive Interface 1	
CONTROL	{Disable, Enable} Enables or disables the installed interface.	RW
DATA RATE (BPS)	Dependant upon interface type. For variable interfaces, this unit must be set by the user. Will not show up on fixed rate interfaces.	RW
INTERFACE	Dependant upon interface type. Selects the interface standard for multiple standard interface card, or displays standard for fixed interfaces.	RW
FRAMING	{Unframed, MPEG188, MPEG204} Used for DVB Interface framing selection. Shows only in DVB Framed Interfaces.	RW

	Note: Only appears when supported by the installed interface.	
JIT CONTROL	{INCH, SLOW, MEDIUM, FAST, STAMP2, STAMP3} Clock recovery DLL speed, or Time-Stamped packets.	RW
NULL PID	{2-Byte Packet ID} Defines the 2-byte packet ID, program ID for null padding packets. This number must match the corresponding receive demux null PID. This number must be unique and not be duplicated by an interface PID or any DVB transport stream PIDs on a framed interface.	RW
	Note: Only appears when using DVB Framed Interfaces such as L0I.	
CLK POLARITY	{Normal, Inverted} Sets the polarity of the clock. Note: Only appears when supported by the installed interface.	RW
DATA INVERT	{Normal, Inverted} Sets the polarity of the data. Note: Only appears when supported by the installed interface.	RW
TERR LOOP	{Normal, Loopback} Interface Loopback	RW
PRBS	{Normal, Ones, PAT001, PRBS2047} Breaks the data path and inserts a pseudo random sequence into the modulators. 'None' is used for normal operation, the others are for Radyne Inc. Corporation configuration.	RW
BUFF ENABLE	{Disable, Enable} Not currently implemented, for future expansion.	RW
CLK SOURCE	{RxClk, Ext BNC, Ext Bal, Internal, TxCLK} Not currently implemented, for future expansion.	RW
CLK FREQ	{2.048 MHz, 5.0 MHz, 10.0 MHz, Data Rate} Not currently implemented, for future expansion.	RW
BUFF DEPTH (MS)	Not currently implemented, for future expansion.	RW

PRESS CLR TO CENTER BUFFER	Centers the buffer.	RW
VOLUME	{0 - 255} Allows the user to set volume level (Orderwire only). Note: Only appears when supported by the installed interface.	RW
BYTE GAP	{0 - 255} Allows the user to set ASI byte gapping. Set to 0 for Burst mode. (ASI Interfaces that support Byte Gap only).	RW
RX INTRFC2	Receive Interface 2. Refer to RX INTRFC1 (menu) for descriptions.	
RX INTRFC3	Receive Interface 3. Refer to RX INTRFC1 (menu) for descriptions.	
RX INTRFC4	Receive Interface 4. Refer to RX INTRFC1 (menu) for descriptions.	

4.4 All Level Menu Screens

4.4.1 Main Menu Screens

Main Menu Screens (one of which is a Title Screen) are listed below:

MM-200 MODULATOR

Title Screen:
Not a modifiable screen.

MODULATOR (menu):

DEMODULATOR (menu):

REPEATER (menu):

APC (menu):

TX INTERFACE (menu):

RX INTERFACE (menu):

MONITOR (menu):

ALARMS (menu):

SYSTEM (menu):

TEST (menu):

4.4.2 MODULATOR (menu) *

The Modulator Menu Screens are listed below:

Screen Name	Selections and Descriptions	L0	L1	L2
FREQUENCY (Hz)	{50 – 90 MHz} Controls the current center band of the	RW	RW	RW

	operating frequency width, or the individual channel frequency if the System Frequency Control is set to 'User'.			
CHANNELS	{Auto, 1 - 4} Controls the number of channel cards where 0 = auto, and 1 – 4 = the number of cards. Increase this number for better performance. Lower this number for better bandwidth efficiency.	RW	RW	RW
SEPARATION	{100% - 150%} Default 125%. Selects the IF Frequency Separation between channels expressed as a percentage of the channel symbol rate or the symbol rate/number of channels.	RW	RW	
DATA RATE (BPS)	{7 – 200 Mbps} Controls the total Data Rate.	RO		
SYMB RATE (SPS)	{3.5 – 28 Msps} Controls the total Symbol Rate.	RW	RW	RO
MODULATION	{QAM4, QAM16, QAM32, QAM64, QAM128, QAM256} Displays the current Modulation Scheme. Performance is increased by using the lowest QAM Mode possible for the required bandwidth.	RW	RW	RO
BANDWIDTH (Hz)	Enters the 3 dB bandwidth of the modulated IF Output. When the radio must meet a particular spectral mask, set this number to something below the masks 3 dB points (i.e. 5% less). For best performance, do not allow the MM200s bandwidth to be greater than the radios 1 dB bandwidth.	RO	RO	RW
UTILIZATION (%) *	Displays the percentage of the data being transferred that is being used by the selected interfaces. Must be less than 100% (Maximize this number for best bandwidth efficiency by lowering the symbol rate, QAM Mode, or the number of channels).	RO	RO	RO
MAX PAYLOAD (Hz)	Displays the maximum total data rate that is useable for the current settings.	RO	RO	RO
SPECTRUM	{Normal, Inverted} Used for inverting the spectrum. If the unit cannot lock to the signal after passing through the radio, try these settings.	RW	RW	RW
TX POWER	{0 to –25 dBm} Sets the IF Output Power in 1 dB steps.	RW	RW	RW
TX ENABLE	{Off, On} Forces the Carrier to Off or On.	RW	RW	RW

4.4.3 DEMODULATOR (menu)

The Demodulator Menu Screens are listed below:

Screen Name	Selections and Descriptions	L0	L1	L2
FREQUENCY (Hz)	{50 – 90 MHz} Displays the current center band of the operating frequency width.	RW	RW	RW
CHANNELS	{Auto, 1 - 4} Controls the number of channel cards where 0 = auto, and 1 – 4 = the number of cards. Increase this number for better performance. Lower this number for better bandwidth efficiency.	RW	RW	RW
SEPARATION	{100% - 150%} Selects the IF Frequency Separation in percent, which is the additional bandwidth percentage that the carrier will cover over the original symbol rate.	RW	RW	
DATA RATE (BPS)	{7 – 200 Mbps} Controls the total Data Rate.	RO		
SYMB RATE (SPS)	{3.5 – 28 Msps} Controls the total Symbol Rate.	RW	RW	RO
DEMODULATION	{QAM4, QAM16, QAM32, QAM64, QAM128, QAM256} Displays the current Demodulation Scheme.	RW	RW	RO
BANDWIDTH (Hz)	Displays the frequency difference between the highest channel's upper 3-dB point and the lowest channel's lower 3-dB point.	RO	RO	RW
UTILIZATION (%)	Displays the percentage of the data being transferred that is being used by the selected interfaces. Must be less than 100%. Maximize this number for best bandwidth efficiency by lowering the symbol rate, QAM Mode, or the number of channels.	RO	RO	RO
MAX PAYLOAD (Hz)	Displays the maximum total data rate that is useable for the current settings.	RO	RO	RO
SPECTRUM	{Normal, Inverted}	RW	RW	RW
ATTENUATION	{0 - 31} Sets the Demodulator Input IF Attenuator in 1 dB steps.	RW	RW	RW
ACQUISITION (menu):	The Demodulator Acquisition Frequency range can be set by the user. This is required at higher QAM rates when using radios with significant frequency drift. As QAM rates increase, the ability of the receiver to acquire to a signal that is offset from the programmed demodulator frequency is reduced. At QAM256 the acquisition window can be as low as ± 50 kHz. Yet at QAM4, the window can be over ± 1 MHz. This range can be further reduced by noise or degraded receive signals. When trying to acquire a signal, the MM200 follows this procedure:			

	<ol style="list-style-type: none"> 1. Try to acquire at the Demodulator Programmed Frequency. 2. Continue to try to Acquire for the length of time set in ACQ DELAY (sec). 3. Step the Demodulator frequency up one step size programmed in ACQ STEP (KHz). 4. Repeat Steps 1 through 3 until the Demodulator Frequency exceeds the + side of the ACQ BW. 5. Set the Demodulator to the negative side of ACQ BW. 6. Repeat until demodulator acquires. Once acquired, the demodulator will have an offset between the frequency at which the demodulator is set and the incoming signal frequency. This is due to demodulator frequency acquisition window and radio drift. This can cause degraded performance and, in the case of radio drift, possible loss of lock. To overcome this, once acquired, the demodulator reduces this offset to 0 Hz by slowly incrementing/decrementing the demodulator frequency. The speed can be adjusted by adjusting the TRACK STEP (Hz). It is suggested that this parameter normally be set to 10 Hz. 			
ACQ CONTROL	{Off, Acquire} Always set to Acquire.	RW	RW	RW
ACQ BW (kHz)	{50 KHz – 400 kHz} Sets the \pm acquisition bandwidth. There is a tradeoff between this number and acquisition speed.	RW	RW	RW
ACQ DELAY (sec)	{10 – 255 sec} Sets the time that the demodulator stays at a frequency before trying the next step.	RW	RW	RW
REACQ DELAY (sec)	{10 – 255 sec} Sets the time that the demodulator remains at frequency after it first loses lock.	RW	RW	RW
ACQ STEP (kHz)	{10 – 100 kHz} Sets the frequency step size the demodulator will take when trying to acquire.	RW	RW	RW

TRACKING STEP (Hz)	{10 – 100 Hz} Sets the step size that the demodulator will use to remove the frequency error of a locked signal. Normally set to 10 Hz.	RW	RW	RW
DIVERSITY (menu):	Diversity			
MODE	{Disable, Auto, Force A, Force B} Controls the diversity mode.	RW	RW	RW
MONITOR (menu):	Diversity channel and FIFO status.			
MUX STATUS	{Unused, Channel A, Channel B, Null Frames} Specifies the multiplexer status.	RW	RW	RW
FIFO A STATUS	{No Flags, Empty, Full} Specifies the status of FIFO A.	RW	RW	RW
FIFO B STATUS	{No Flags, Empty, Full} Specifies the status of FIFO B.	RW	RW	RW
CHANNEL A ERR	Displays the Channel A error counter.	RO	RO	RO
CHANNEL B ERR	Displays the Channel B error counter.	RO	RO	RO
CHANNEL AB ERR	Displays the Channel A and B error counter.	RO	RO	RO

4.4.4 REPEATER (menu)

The Repeater Menu Screen is listed below:

Screen Name	Selections and Descriptions	L0	L1	L2
MODE	{Off, On} Enables the repeater feature.	RW	RW	RW

4.3.4 APC (Menu)

The primary APC screen is listed below:

Screen Name	Selections and Descriptions	L0	L1	L2
TRANSMIT (menu):	APC Transmit settings.			
XMT CONTROL	{TXDOWN, TXUP, AUTO} Controls the local TX level.	RW	RW	RW
MAX TX LEVEL	Sets the maximum TX power level.	RW	RW	RW
MIN TX LEVEL	Displays the minimum TX power level.	RO	RO	RO
DEF TX LEVEL	Sets the default TX power level.	RW	RW	RW
STEP SIZE	Sets the TX power step size.	RW	RW	RW
APC RANGE	Sets the TX APC range	RW	RW	RW
APC SPEED	Sets the TX power step speed.	RW	RW	RW
RECEIVE (menu):	APC Receive settings.			
RCV CONTROL	{RXDOWN, RXUP, AUTO} Controls the remote TX level.	RW	RW	RW
LEVEL (dBm)	Desired RX power level.	RW	RW	RW
HYSTERESIS	APC Hysteresis.	RW	RW	RW
MONITOR (menu):	APC Monitor.			
XMT STATUS	{NOCHANGE, TXDOWN, TXUP} Displays APC transmit status.	RO	RO	RO
RCV STATUS	{NOCHANGE, RXDOWN, RXUP} Displays APC receive status.	RO	RO	RO

4.4.5 TX INTERFACE (Menu)

The primary Tx Interface Screens and their sub-menus as listed below:

Screen Name	Selections and Descriptions	L0	L1	L2
TX INTRFC1 (menu):	Transmit Interface 1			
CONTROL	{Disable, Enable} Enables or disables the installed interface.	RW	RW	RW
DATA RATE (BPS)	Dependant upon interface type. For variable interfaces, this unit must be set by the user. Will not show up on fixed rate interfaces.	RW	RW	RW
INTERFACE	Dependant upon interface type. Selects the interface standard for multiple standard interface card, or displays standard for fixed interfaces.	RW	RW	RW
FRAMING	{Unframed, MPEG188, MPEG204} Used for DVB Interface framing selection. Shows only in DVB Framed Interfaces. <i>Note: Only appears when supported by the installed interface.</i>	RW	RW	RW
JIT CONTROL	{NORMAL, STAMP2, STAMP3} Normal or Time-Stamped packets.	RW	RW	RW
NULL PID	{2-Byte Packet ID} Defines the 2-byte packet ID, program ID for null padding packets. This number must match the corresponding receive demux null PID. This number must be unique and not be duplicated by an interface PID or any DVB transport stream PIDs on a framed interface. <i>Note: Only appears when using DVB Framed Interfaces such as L0I.</i>	RW	RW	RW
PID	Interface Packet ID. This number must match the corresponding interface at the Rx site. This number must be unique and not duplicated on other Tx interfaces.	RW		
CLK POLARITY	{Normal, Inverted} Sets the polarity of the clock. <i>Note: Only appears when supported by the installed interface.</i>	RW	RW	RW
DATA INVERT	{Normal, Inverted} Sets the polarity of the data.	RW	RW	RW
BB LOOP	{Normal, Inverted} Baseband Loopback. <i>Not yet</i>	RW	RW	RW

VOLUME	<i>implemented, for future expansion.</i> {0 - 255} Allows the user to set volume level (Orderwire only).	RW	RW	RW
TX INTRFC2 (menu)	Transmit Interface 2. Refer to TX INTRFC1 (menu) for descriptions.			
TX INTRFC3 (menu)	Transmit Interface 3. Refer to TX INTRFC1 (menu) for descriptions.			
TX INTRFC4 (menu)	Transmit Interface 4. Refer to TX INTRFC1 (menu) for descriptions.			

4.4.6 RX INTERFACE (Menu)

The primary Rx Interface Screens and their sub-menus as listed below:

Screen Name	Selections and Descriptions	L0	L1	L2
RX INTRFC1	Receive Interface 1			
CONTROL	{Disable, Enable} Enables or disables the installed interface.	RW	RW	RW
DATA RATE (BPS)	Dependant upon interface type. For variable interfaces, this unit must be set by the user. Will not show up on fixed rate interfaces.	RW	RW	RW
INTERFACE	Dependant upon interface type. Selects the interface standard for multiple standard interface card, or displays standard for fixed interfaces.	RW	RW	RW
FRAMING	{Unframed, MPEG188, MPEG204} Used for DVB Interface framing selection. Shows only in DVB Framed Interfaces. Note: Only appears when supported by the installed interface.	RW	RW	RW
JIT CONTROL	{INCH, SLOW, MEDIUM, FAST, STAMP2, STAMP3} Clock recovery DLL speed, or Time-Stamped packets.	RW	RW	RW
NULL PID	{2-Byte Packet ID} Defines the 2-byte packet ID, program ID for null padding packets. This number must match the corresponding receive demux null PID. This number must be unique and not be duplicated by an interface PID or any DVB transport stream PIDs on a framed interface. Note: Only appears when using DVB Framed Interfaces such as L0I.	RW	RW	RW
PID	Interface Packet ID. This number must match the corresponding interface at the Rx site. This number must be unique and not duplicated on other Tx interfaces.	RW		
CLK POLARITY	{Normal, Inverted} Sets the polarity of the clock. Note: Only appears when supported by the installed interface.	RW	RW	RW
DATA INVERT	{Normal, Inverted} Sets the polarity of the data. Note: Only appears when supported	RW	RW	RW

	<i>by the installed interface.</i>			
TERR LOOP	{Normal, Loopback} <i>Not yet implemented, for future expansion.</i>	RW	RW	RW
BUFF ENABLE	{Disable, Enable} <i>Not yet implemented, for future expansion.</i>	RW	RW	RW
CLK SOURCE	{RxClk, Ext BNC, Ext Bal, Internal, TxCLK} <i>Not yet implemented, for future expansion.</i>	RW	RW	RW
CLK FREQ	{2.048 MHz, 5.0 MHz, 10.0 MHz, Data Rate} <i>Not yet implemented, for future expansion.</i>	RW	RW	RW
BUFF DEPTH (MS)	<i>Not yet implemented, for future expansion.</i>	RW	RW	RW
PRESS CLR TO CENTER BUFFER	Centers the buffer.	RW	RW	RW
	<i>Note: Rx Interface between Data and Volume may need to be masked off until needed.</i>			
VOLUME	{0 - 255} Allows the user to set volume level (Orderwire only). <i>Note: Only appears when supported by the installed interface.</i>	RW	RW	RW
BYTE GAP	{0 - 255} Allows the user to set ASI byte gapping. Set to 0 for Burst mode. (ASI Interfaces that support Byte Gap only).	RW	RW	RW
RX INTRFC2	Receive Interface 2. Refer to RX INTRFC1 (menu) for descriptions.			
RX INTRFC3	Receive Interface 3. Refer to RX INTRFC1 (menu) for descriptions.			
RX INTRFC4	Receive Interface 4. Refer to RX INTRFC1 (menu) for descriptions.			

4.4.7 MONITOR (Menu)

The Monitor Screens and their sub-menus are listed below. Those marked with an asterisk (*) are used for detailed system debug when consulting with Radyne Inc. .

Screen Name	Selections and Descriptions	L0	L1	L2
MON MOD (menu)	Monitors the state of the modulator.			

TX ENABLED	OFF, ON} Displays TX Power Control Status	RO	RO	RO
INSTALLED CHs	{0 – 4} Displays number of installed channels	RO	RO	RO
MON DMD (menu):	Monitors the state of the demodulator.	RO	RO	RO
DMD SNR X 10	{000 – 999 000 – 999 000 – 999 000 - 999} Displays the demodulator signal-to-noise ratio for each channel. Divide each number by 10 to get the dB value (i.e. 355 = 35.5 dB).			
DMD AGC	{000 – 655 000 – 655 000 – 655 000 - 655} Displays a relative indication of the AGC level of each channel. Optimum performance is approximately 320 – 420. The lower the number, the higher the IF signal.	RO	RO	RO
LEVEL (dBm)	Monitors the aggregate input level in dBm.	RO	RO	RO
LEVEL 1&2 (dBm)	Monitor channels 1 and 2 input levels in dBm.	RO	RO	RO
LEVEL 3&4 (dBm)	Monitor channels 3 and 4 input levels in dBm.	RO	RO	RO
PRE FEC1 BER	Displays channel 1 pre FEC BER.	RO	RO	RO
POST FEC1 BER	Displays channel 1 post FEC BER.	RO	RO	RO
PRE FEC2 BER	Displays channel 2 pre FEC BER.	RO	RO	RO
POST FEC2 BER	Displays channel 2 post FEC BER.	RO	RO	RO
PRE FEC3 BER	Displays channel 3 pre FEC BER.	RO	RO	RO
POST FEC3 BER	Displays channel 3 post FEC BER.	RO	RO	RO
PRE FEC4 BER	Displays channel 4 pre FEC BER.	RO	RO	RO
POST FEC4 BER	Displays channel 4 post FEC BER.	RO	RO	RO
DMD1 STATE	{Locked, Unlocked}	RO	RO	RO
DMD2 STATE	{Locked, Unlocked}	RO	RO	RO
DMD3 STATE	{Locked, Unlocked}	RO	RO	RO
DMD4 STATE	{Locked, Unlocked}	RO	RO	RO

OFFST FRQ1	Displays channel 1 offset frequency	RO	RO	RO
OFFST FRQ2	Displays channel 2 offset frequency	RO	RO	RO
OFFST FRQ3	Displays channel 3 offset frequency	RO	RO	RO
OFFST FRQ4	Displays channel 4 offset frequency	RO	RO	RO
INSTALLED CHs	{0 – 4} Displays number of installed channels	RO	RO	RO
MON MUX (menu)	Monitors the multiplexor			
TX INTF1 RATE	Interface 1 tx data rate (KBPS)	RO	RO	RO
TX INTF2 RATE	Interface 2 tx data rate (KBPS)	RO	RO	RO
TX INTF3 RATE	Interface 3 tx data rate (KBPS)	RO	RO	RO
TX INTF4 RATE	Interface 4 tx data rate (KBPS)	RO	RO	RO
MON DMX (menu)	Monitors the demultiplexor			
RX INTF1 RATE	Interface 1 rx data rate (KBPS)	RO	RO	RO
RX INTF2 RATE	Interface 2 rx data rate (KBPS)	RO	RO	RO
RX INTF3 RATE	Interface 3 rx data rate (KBPS)	RO	RO	RO
RX INTF4 RATE	Interface 4 rx data rate (KBPS)	RO	RO	RO
MON COM (menu)	Monitors the common state.			
INTERFACE 1	Specifies Interface 1 type.	RO	RO	RO
INTERFACE 2	Specifies Interface 2 type.	RO	RO	RO
INTERFACE 3	Specifies Interface 3 type.	RO	RO	RO
INTERFACE 4	Specifies Interface 4 type.	RO	RO	RO

EVENT BUFF	{Empty, Number of events} Displays the number of events that has occurred and the event log. The event log is the history of events recorded in the event buffer. A maximum of 40 events may be stored in the buffer. Upon receipt of the 41 st event, the first received event is automatically deleted, and so on, maintaining the maximum 40 events.	RO	RO	RO
PRESS CLR TO ERASE EVENTS	Removes all events from the buffer.	RW	RW	RW

4.4.8 ALARMS (Menu)

The primary Alarm Menus are listed below:

Screen Name	Selections and Descriptions	L0	L1	L2
ACTIVE ALRMS (menu)	Current alarms.			
LATCHED ALRM (menu)	Previous alarms that have been logged.			
CLEAR ALARMS	{Ent=Y, Clr=N} Clears all latched alarms.			

4.4.8.1 Active Alarms

The Active Alarm Screens are listed below, including those related to the FPGA (Field Programmable Gate Array):

Screen Name	Selections and Descriptions	L0	L1	L2
MAJOR TX (menu)	An alarm that will terminate transmissions. Red LED will illuminate.			
MOD HW GLUE	{Masked, Unmasked} FPGA failure.	RO	RO	RO
MOD HW DATA	{Masked, Unmasked} FPGA failure.	RO	RO	RO
MDD0 HW FPGA	{Masked, Unmasked} FPGA failure.	RO	RO	RO
MDD1 HW FPGA	{Masked, Unmasked} FPGA failure.	RO	RO	RO
MDD2 HW FPGA	{Masked, Unmasked} FPGA failure.	RO	RO	RO
MDD3 HW FPGA	{Masked, Unmasked} FPGA failure.	RO	RO	RO
MDD0 PLLLOCK	{Masked, Unmasked} RF PLL not locked.	RO	RO	RO

MDD1 PLLLOCK	{Masked, Unmasked} RF PLL not locked.	RO	RO	RO
MDD2 PLLLOCK	{Masked, Unmasked} RF PLL not locked.	RO	RO	RO
MDD3 PLLLOCK	{Masked, Unmasked} RF PLL not locked.	RO	RO	RO
MAJOR RX (menu)	An alarm that will terminate reception. Red LED will illuminate.			
DMD HW GLUE	FPGA failure.	RO	RO	RO
DMD HW DATA	FPGA failure.	RO	RO	RO
SIGNAL LOCK	Monitors the system signal lock states.	RO	RO	RO
SYNC LOCK	Monitors the system sync lock states.	RO	RO	RO
DAT PLL LOCK	Monitors the data PLL lock states.	RO	RO	RO
DIVERSITY FPGA	FPGA failure.	RO	RO	RO
DDD0 HW FPGA	FPGA failure.	RO	RO	RO
DDD1 HW FPGA	FPGA failure.	RO	RO	RO
DDD2 HW FPGA	FPGA failure.	RO	RO	RO
DDD3 HW FPGA	FPGA failure.	RO	RO	RO
DDD0 PLLLOCK	RF PLL not locked.	RO	RO	RO
DDD1 PLLLOCK	RF PLL not locked.	RO	RO	RO
DDD2 PLLLOCK	RF PLL not locked.	RO	RO	RO
DDD3 PLLLOCK	RF PLL not locked.	RO	RO	RO
MAJOR MUX (menu)	An alarm that will terminate mux operations. Red LED will illuminate.			
MUX HW FPGA	FPGA failure.	RO	RO	RO
INT0 HW FPGA	FPGA failure.	RO	RO	RO
INT2 HW FPGA	FPGA failure.	RO	RO	RO
INT3 HW FPGA	FPGA failure.	RO	RO	RO
INT4 HW FPGA	FPGA failure.	RO	RO	RO

MAJOR DMX (menu)	An alarm that will terminate demux operations. Red LED will illuminate.			
DMX HW FPGA	FPGA failure.	RO	RO	RO
INT0 HW FPGA	FPGA failure.	RO	RO	RO
INT2 HW FPGA	FPGA failure.	RO	RO	RO
INT3 HW FPGA	FPGA failure.	RO	RO	RO
INT4 HW FPGA	FPGA failure.	RO	RO	RO
MINOR TX (menu):	An alarm that will not terminate transmissions. Yellow LED will illuminate.			
FRAME LOCK	Modulator frame detect.	RO	RO	RO
CHANNEL 1 (menu)				
LOOP LOCK	Modulator tracking.	RO	RO	RO
FEC LOCK	Modulator has a valid sync lock.	RO	RO	RO
FIFO FULL	Modulator FIFO overflow.	RO	RO	RO
FIFO EMPTY	Modulator FIFO underflow.	RO	RO	RO
FIFO ACTIVE	Modulator FIFO active.	RO	RO	RO
CHANNEL 2 (menu)	Refer to CHANNEL 0 (menu) for descriptions.			
CHANNEL 3 (menu)	Refer to CHANNEL 0 (menu) for descriptions.			
CHANNEL 4 (menu)	Refer to CHANNEL 0 (menu) for descriptions.			
MINOR RX (menu)	An alarm that will not terminate reception. Yellow LED will illuminate.			
CHANNEL 1 (menu)				
QAM LOCK	Demod channel constellation lock.	RO	RO	RO
FEC LOCK	Demod channel sync and FEC lock.	RO	RO	RO
FIFO FULL	Demod channel FIFO overflow.	RO	RO	RO
FIFO EMPTY	Demod channel FIFO underflow.	RO	RO	RO
SYNC LOCK	Demod channel loss of sync byte.	RO	RO	RO
FIFO RELOAD	Indicates the FIFO state.	RO	RO	RO
FIFO POS	Skew detector.	RO	RO	RO
	FIFO Tracking error	RO	RO	RO

TRACK FAULT				
CHANNEL 2 (menu)	Refer to CHANNEL 0 (menu) for descriptions.			
CHANNEL 3 (menu)	Refer to CHANNEL 0 (menu) for descriptions.			
CHANNEL 4 (menu)	Refer to CHANNEL 0 (menu) for descriptions.			
APC (menu)				
RCV OVERRUN	APC Receive overrun error	RO	RO	RO
CMD INVALID	APC Invalid command received	RO	RO	RO
MINOR MUX (menu)	An alarm that will not terminate mux operations. Red LED will illuminate.			
MINOR INT1 (menu)				
CLK ACTIVITY	No clock activity on Tx Interface channel.	RO	RO	RO
DAT ACTIVITY	No data activity on Tx Interface channel.	RO	RO	RO
FIFO FULL	Tx Interface FIFO overflow.	RO	RO	RO
FIFO EMPTY	Tx Interface FIFO underflow.	RO	RO	RO
FRAME VALID	Tx Interface MPEG framing.	RO	RO	RO
SIGNAL LOSS	Tx Interface loss of signal.	RO	RO	RO
MINOR INT2 (menu)	Refer to MINOR INT0 (menu) for descriptions.			
MINOR INT3 (menu)	Refer to MINOR INT0 (menu) for descriptions.			
MINOR INT4 (menu)	Refer to MINOR INT0 (menu) for descriptions.			
MINOR DMX (menu)	An alarm that will not terminate demux operations. Yellow LED will illuminate.			
DMX SYNCLOCK	Demux is not receiving valid packets.	RO	RO	RO
MINOR INT1 (menu)				
CLK ACTIVITY	No Rx channel packet activity.	RO	RO	RO
DAT ACTIVITY	No Rx channel data activity.	RO	RO	RO
FIFO FULL	Rx channel FIFO overflow.	RO	RO	RO
FIFO EMPTY	Rx channel FIFO underflow.	RO	RO	RO
PLL LOCK				

MINOR INT2 (menu)	Buffer clock PLL not locked.	RO	RO	RO
MINOR INT3 (menu)	Refer to MINOR INT0 (menu) for descriptions.			
MINOR INT4 (menu)	Refer to MINOR INT0 (menu) for descriptions. Refer to MINOR INT0 (menu) for descriptions.			
COMMON (menu)	An alarm that affects both transmit and receive.			
GLUE HW FPGA	FPGA failure. Refer to Section 6.1.	RO	RO	RO
TEST HW FPGA	FPGA failure. Refer to Section 6.1.	RO	RO	RO

4.4.8.2 Latched Alarms

The Latched Alarm Screens are the same as Active Alarms Screens. Refer to Section 4.1.7.1 for descriptions.

4.4.8.3 Clear Alarms

The Clear Alarms Screen clears the currently latched alarms.

4.4.9 SYSTEM (Menu)

The System Screens are listed below:

Screen Name	Selections and Descriptions	L0	L1	L2
CONTROL MODE	{Front Panel, Computer} Allows the user to choose whether the system is controlled from the Front Panel or via a remote computer.	RW	RW	RW
USER MODE	{Level 0, Level 1, Level 2} Depending upon the setting, allows the user to have access to all system parameters, or operate at Levels 1 or 2 control.	RW	RW	RW
DEBUG MODE	{Off, On} Allows the user to turn on or off the Debug Mode	RW		
LAST RATE	{Symbol, Data, Auto} Allows the user to give precedence to symbol rate or data rate (which remains constant while the other varies). Auto allows both to vary.	RW		
FREQ PLAN	Controls the user frequency plan.	RW		
APC ENABLE	{Off, On} Controls APC subsystem.	RW	RW	RW
MAX MODULATION	{QAM4, QAM16, QAM32, QAM64, QAM128, QAM256} Controls the maximum allowable modulation for automatic calculations.	RW	RW	RW

ALL ALARMS	{No, Yes} Used for dispersive fading analyzer testing.	RW	RW	RW
DATE	{YY/MM/DD} Allows the user to enter the current date.	RW	RW	RW
TIME	{HH:MM:SS} Allows the user to enter the current time.	RW	RW	RW
FRONT PANEL (menu)				
LEVEL	{Low, Mid, High, Off} Set the front panel backlight intensity level.	RW	RW	RW
TIMEOUT	{0 – 99} Allows the user to enter the amount of time in seconds for the backlight to dim. Enter '0' for no timeout.	RW	RW	RW
KEY CLICK	{On, Off} Allows the user to choose between silent and audible button depression.	RW	RW	RW
REMOTE PORT (menu)				
REMOTE ADDR	Sets the multidrop address of the remote port.	RW	RW	RW
REMOTE BAUD	Sets the baud rate of the remote port.	RW	RW	RW
REMOTE LINE	{RS485, RS232} Sets line control for remote port.	RW	RW	RW
TERMINAL (menu)				
TERM BAUD	Sets the baud rate of the terminal port.	RW	RW	RW
EMULATION	{VT 100, WYSE 50, ADDS VP} Allows the system to emulate an ASCII dumb terminal.	RW	RW	RW
HW/FW CONFIG (menu)				
LOAD DEFAULT (menu)	Allows the user to set the system configuration to default settings. This selection is password protected.			
PASSWORD	Password field for enabling the default system configuration overwrite.	RW	RW	RW
DEBUG MODE (menu)	Allows the user to enable the Debug Mode (this selection is password protected).			
DBG PASSWORD	Password field for enabling the debug mode (factory use only).	RW	RW	RW
SNMP DEFAULT (menu)	Allows the user to set the SNMP Controls to the default settings.			
SNMP PASSWORD	Password field to set the SNMP defaults.	RW	RW	RW

FW4459--	Firmware Version	RO	RO	RO
FW4459--	Firmware Date	RO	RO	RO

4.4.10 TEST (Menu)

The Test Screens are listed below:

Screen Name	Selections and Descriptions	L0	L1	L2
LED TEST	{On, Off} Illuminates all LEDs on front panel.	RW	RW	RW
MUX DMX LOOP	{Normal, Mux Dmx Loop, Mux, Dmx LVDS, Modem LVDS, Repeater} Tests multiplexer and demultiplexer function.	RW	RW	RW
RF LOOPBK	{NORMAL, LOOPBACK} Tests modulator and demodulator function.	RW	RW	RW
CARRIER	{Normal, CW, Offset 1 Hz, 100 kHz, 3.5 MHz, Sweep Up, Sweep Dn} Sets the carrier to normal pure carrier output, or sweep test modes.	RW	RW	RW
PRBS:	{None, 2¹⁵, 2¹⁵M, 2²³, 2²³M} Breaks the data path and inserts a pseudo random sequence into the modulators. 'None' is used for normal operation, the others are for Radyne Inc. configuration.	RW	RW	RW
REMOTE TAPS	{NORMAL, 1:1, 1:10, 1:100} Remote Tap Enable	RW	RW	RW
AGC BW	{6} Set to 6 for normal operation.	RW	RW	RW

4.5 Remote Port User Interface

The Remote Port of the MM200 allows for complete control and monitor functions via an RS-485 Serial Interface.

Control and status messages are conveyed between the MM200 and the subsidiary modems, and the host computer using packetized message blocks in accordance with a proprietary communications specification. This communication is handled by the Radyne Link Level Protocol (RLLP), which serves as a protocol 'wrapper' for the M&C data.

Complete information on monitor and control software is contained in the following sections.

4.5.1 Protocol Structure



When new features are added to Radyne Inc. equipment, the control parameters are appended to the end of the Non-Volatile Section of the Remote Communications Specification, and status of the features, if any, are added at the end of the Volatile Section. If a remote M&C queries two pieces of Radyne Inc. equipment with different revision software, they could respond with two different sized packets. The remote M&C MUST make use of the non-volatile count value to index to the start of the Volatile Section. If the remote M&C is not aware of the newly added features to the product, it should disregard the parameters at the end of the Non-Volatile Section and index to the start of the Volatile Section.

Before creating any software based on the information contained in this document, contact the Radyne Inc. Customer Service Department (602-437-9620) to find out if the software revision for that piece of equipment is current and that no new features have been added since the release of this document.

The Communications Specification (COMMSPEC) defines the interaction of computer resident Monitor and Control software used in satellite earth station equipment such as modems, redundancy switches, multiplexers, and other ancillary support gear. Communication is bi-directional, and is normally established on one or more full-duplex multi-drop control buses that conform to EIA Standard RS-485.

Each piece of earth station equipment on a control bus has a unique physical address, which is assigned during station setup/configuration or prior to shipment. Valid decimal addresses on one control bus range from 032 through 255 for a total of up to 224 devices per bus. Address 255 of each control bus is usually reserved for the M&C computer.

4.5.2 Protocol Wrapper

The Radyne Inc. COMMSPEC is byte-oriented, with the Least Significant Bit (LSB) issued first. Each data byte is conveyed as mark/space information with two marks comprising the stop data. When the last byte of data is transmitted, a hold comprises one steady mark (the last stop bit). To begin or resume data transfer, a space substitutes this mark. This handling scheme is controlled by the hardware and is transparent to the user. A pictorial representation of the data and its surrounding overhead may be shown as follows:

S1	S2	B ₀	B ₁	B ₂	B ₃	B ₄	B ₅	B ₆	B ₇	S1	S2, etc.
----	----	----------------	----------------	----------------	----------------	----------------	----------------	----------------	----------------	----	-------------

The stop bits, S1 and S2, are each a mark. Data flow remains in a hold mode until S2 is replaced by a space. If S2 is followed by a space, it is considered a start bit for the data byte and not part of the actual data (B₀ - B₇).

The COMMSPEC developed for use with the Radyne Inc. Link Level Protocol (RLLP) organizes the actual monitor and control data within a shell, or "protocol wrapper", that surrounds the data.

The format and structure of the COMMSPEC message exchanges are described herein. Decimal numbers have no suffix; hexadecimal numbers end with a lower case h suffix and binary values have a lower case b suffix. Thus, 22 = 16h = 000010110b. The principal elements of a data frame, in order of occurrence, are summarized as follows:

<SYN> - the message format header character, or ASCII sync character, that defines the beginning of a message. The <SYN> character value is always 16h.

<BYTE COUNT> - the Byte Count is the number of bytes in the <DATA> field, ranging from 0 through TBD. This field is 2 bytes long for the MM200 protocol.

<SOURCE ID> - the Source Identifier defines the message originator's multidrop address. Note that all nodes on a given control bus have a unique address that must be defined.

<DESTINATION ID> - The Destination Identifier specifies the multidrop address of the device(s) to which the message is sent.

<FRAME SEQUENCE NUMBER> - The FSN is a tag with a value from 0 through 255 that is sent with each message. It assures sequential information framing and correct equipment acknowledgment and data transfers.

<OPCODE> - The Operation Code field contains a number that identifies the message type associated with the data that follows it. Acknowledgment and error codes are returned in this field. This field is 2 Bytes for the MM200 protocol.

<...DATA...> - The Data field contains the binary, data bytes associated with the <OPCODE>. The number of data bytes in this field is indicated by the <BYTE COUNT> value.

<CHECKSUM> - The checksum is the modulo 256 sum of all preceding message bytes, excluding the <SYN> character. The checksum determines the presence or absence of errors within the message. In a message block with the following parameters, the checksum is computed as shown below in Table 4-4.

Table 4-4. Checksum Calculation Example		
BYTE FIELD	DATA CONTENT	RUNNING CHECKSUM
<BYTE COUNT> (Byte 1)	00h = 00000000b	00000000b
<BYTE COUNT> (Byte 2)	02h = 00000010b	00000010b
<SOURCEID>	F0h = 11110000b	11110010b
<DESTINATION ID>	2Ah = 00101010b	00011100b
<FSN>	09h = 00001001b	00100101b
<OPCODE> (Byte 1)	00h = 00000000b	00101000b
<OPCODE> (Byte 2)	03h = 00000011b	00101000b
<DATA> (Byte 1)	DFh = 11011111b	00000111b
<DATA> (Byte 2)	FEh = 11111110b	00000101b

Thus, the checksum is 00000101b; which is 05h or 5 decimal. Alternative methods of calculating the checksum for the same message frame are:

$$00h + 02h + F0h + 2Ah + 09h + 00h + 03h + DFh + FEh = 305h.$$

Since the only concern is the modulo 256 (modulo 100h) equivalent (values that can be represented by a single 8-bit byte), the checksum is 05h.

For a decimal checksum calculation, the equivalent values for each information field are:

$$0 + 2 + 240 + 42 + 9 + 0 + 3 + 223 + 254 = 773;$$

$773/256 = 3$ with a remainder of 5. This remainder is the checksum for the frame.

$$5 \text{ (decimal)} = 05h = 0101b = \text{<CHECKSUM>}$$

4.5.3 Frame Description and Bus Handshaking

In a Monitor and Control environment, every message frame on a control bus port executes as a packet in a loop beginning with a wait-for-SYN-character mode. The remaining message format header information is then loaded, either by the M&C computer or by a subordinate piece of equipment requesting access to the bus. Data is processed in accordance with the OPCODE, and the checksum for the frame is calculated. If the anticipated checksum does not match then the wait-for-SYN mode goes back into effect. If the OPCODE resides within a command message, it defines the class of action that denotes an instruction that is specific to the device type, and is a prefix to the DATA field if data is required. If the OPCODE resides within a query message packet, then it defines the query code, and can serve as a prefix to query code DATA.

The Frame Sequence Number (FSN) is included in every message packet, and increments sequentially. When the M & C computer or bus-linked equipment initiates a message, it assigns the FSN as a tag for error control and handshaking. A different FSN is produced for each new message from the FSN originator to a specific device on the control bus. If a command packet is sent and not received at its intended destination, then an appropriate response message is not received by the packet originator. The original command packet is then re-transmitted with the same FSN. If the repeated message is received correctly at this point, it is considered a new message and is executed and acknowledged as such.

If the command packet is received at its intended destination but the response message (acknowledgment) is lost, then the message originator (usually the M&C computer) re-transmits the original command packet with the same FSN. The destination device detects the same FSN and recognizes that the message is a duplicate, so the associated commands within the packet are not executed a second time. However, the response packet is again sent back to the source as an acknowledgment in order to preclude undesired multiple executions of the same command.

To reiterate, valid equipment responses to a message require the FSN tag in the command packet. This serves as part of the handshake/acknowledge routine. If a valid response message is absent, then the command is re-transmitted with the same FSN. For a repeat of the same command involving iterative processes (such as increasing or decreasing transmit power level), the FSN is incremented after each message packet. When the FSN value reaches 255, it overflows and begins again at zero.

The full handshake/acknowledgment involves a reversal of source and destination ID codes in the next message frame, followed by a response code in the <OPCODE> field of the message packet from the equipment under control.

4.5.4 Global Response Operational Codes

In acknowledgment response packets, the operational code <OPCODE> field of the message packet is set to 0 by the receiving devices when the message intended for the device is evaluated as valid. The device that receives the valid message then exchanges the <SOURCE ID> with the <DESTINATION ID>, sets the <OPCODE> to zero in order to indicate that a good message was received, and returns the packet to the originator. This "GOOD MESSAGE" Opcode is one of nine global responses. Global response Opcodes are common responses, issued to the M&C computer or to another device, that can originate from and are interpreted by all Radyne Inc. equipment in the same manner. These are summarized as follows all Opcode values are expressed in decimal form:

Table 4-5. Response OPCODES	
RESPONSE OPCODE DESCRIPTION	OPCODE
Good Message	000d = 0x0000
Bad Parameter	255d = 0x00FF
Bad Opcode	254d = 0x00FE
Bad Checksum	253d = 0x00FD
Command Not Allowed in LOCAL Mode	252d = 0x00FC
Command Not Allowed in AUTO Mode	251d = 0x00FB
Bad Destination	250d = 0x00FA
Unable to Process Command	249d = 0x00F9
Packet Too Long	248d = 0x00F8

The following response error codes are specific to the MM200:

MM200 Response Error Code Descriptions	OPCODE
REMOTE_GOOD	0x0000
REMOTE_SIZE_ERROR	0x0201
REMOTE_UNKNOWN_ERROR	0x0202
REMOTE_CONTROL_ERROR	0x0203
REMOTE_PARAMETER_ERROR	0x0204
REMOTE_LASRATE_ERROR	0x0205
REMOTE_SYMBOL_LO_ERROR	0x0206
REMOTE_SYMBOL_HI_ERROR	0x0207
REMOTE_DATA_LO_ERROR	0x0208
REMOTE_DATA_HI_ERROR	0x0209
REMOTE_FRAMING_ERROR	0x020A
REMOTE_MODULATION_ERROR	0x020B
REMOTE_DEMODULATION_ERROR	0x020C
REMOTE_CHANNEL_ERROR	0x0210

REMOTE_PID_ERROR	0x0211
REMOTE_DATA_RATE_ERROR	0x0212
REMOTE_INTERFACETYPE_ERROR	0x0213
REMOTE_SUBTYPE_ERROR	0x0214
REMOTE_CLOCKSOURCE_ERROR	0x0215
REMOTE_CLOCKFREQUENCY_ERROR	0x0216
REMOTE_FRAMING_ERROR	0x0217
REMOTE_VOLUME_ERROR	0x0218
REMOTE_CLOCKPOLARITY_ERROR	0x0219
REMOTE_DATAINVERTERROR	0x021A
REMOTE_BBLOOPACK_ERROR	0x021B
REMOTE_TERRLOOPBACK_ERROR	0x021C
REMOTE_PRBS_ERROR	0x021D
REMOTE-INTERFACEENABLE_ERROR	0x021E
REMOTE_FREQUENCY_ERROR	0x021F
REMOTE_FREQUENCY1_ERROR	0x0220
REMOTE_FREQUENCY2_ERROR	0x0221
REMOTE_FREQUENCY3_ERROR	0x0222
REMOTE_FREQUENCY4_ERROR	0x0223
REMOTE_FREQUENCYPLAN_ERROR	0x0224
REMOTE_USERMODE_ERROR	0x0225
REMOTE_BANDWIDTH_ERROR	0x0226
REMOTE_UTILIZATION_ERROR	0x0227
REMOTE_CHANNELLOCKED_ERROR	0x0228
REMOTE_CHANNELNOTLOCKED_ERROR	0x0229
REMOTE_NOINTERFACECARD_ERROR	0x022A
REMOTE_ACQUISITIONCONTROL_ERROR	0x022B
REMOTE_ACQUISITIONBANDWIDTH_ERROR	0x022C
REMOTE_ACQUISITIONDELAY_ERROR	0x022D
REMOTE_ACQUISITIONSTEP_ERROR	0x022E
REMOTE_TRACKINGSTEP_ERROR	0x022F
REMOTE_REAQUISITIONDELAY_ERROR	0x0230
REMOTE_CAPABILITY_ERROR	0x0231
REMOTE_RANGE_ERROR	0x0232
REMOTE_LORANGE_ERROR	0x0233
REMOTE_HIRANGE_ERROR	0x0234

REMOTE_SYMBOLRATE_PERCHANNEL_LO_ERROR	0x0235
REMOTE_SYMBOLRATE_PERCHANNEL_HI_ERROR	0x0236
REMOTE_NOTCOMPATIBLE_ERROR	0x0237
REMOTE_MM200_IN_REPEATER_MODE_ERROR	0x0238
REMOTE_DIVERSITY_ERROR	0x023A
REMOTE_CLEARBER_ERROR	0x023B

4.5.5 Collision Avoidance

When properly implemented, the physical and logical devices and ID addressing scheme of the COMMSPEC normally precludes message packet contention on the control bus. The importance of designating unique IDs for each device during station configuration cannot be overemphasized. One pitfall, which is often overlooked, concerns multi - drop override IDs. All too often, multiple devices of the same type are assigned in a direct - linked "single - thread" configuration accessible to the M&C computer directly. For example, if two MM200 Modems with different addresses DESTINATION IDs are linked to the same control bus at the same hierarchical level, both will attempt to respond to the M&C computer when the computer generates a multi - drop override ID of 1. If their actual setup parameters, status, or internal timing differs, they will both attempt to respond to the override simultaneously with different information, or asynchronously in their respective message packets and response packets, causing a collision on the serial control bus.

To preclude control bus data contention, different IDs must always be assigned to the equipment. If two or more devices are configured for direct - linked operation, then the M&C computer and all other devices configured in the same manner must be programmed to inhibit broadcast of the corresponding multi - drop override ID.

The multi - drop override ID is always accepted by devices of the same type on a common control bus, independent of the actual DESTINATION ID. These override IDs with the exception of "BROADCAST" are responded to by all directly linked devices of the same type causing contention on the bus. The "BROADCAST" ID, on the other hand, is accepted by all equipment but none of them returns a response packet to the remote M&C.

The following multi - drop override IDs are device - type specific, with the exception of "BROADCAST". These are summarized below with ID values expressed in decimal notation:

Table 4-6. Broadcast IDs	
Directly - Addressed Equipment	Multi - Drop Override ID
Broadcast all directly - linked devices	00
DMD - 3000/4000, 4500 or 5000 Mod Section, DMD15	01
DMD - 3000/4000, 4500 or 5000 Demod Section, DMD15	02
RCU - 340 1:1 Switch	03
RCS - 780 1:N Switch	04
RMUX - 340 Cross - Connect Multiplexer	05
CDS - 780 Clock Distribution System	06
SOM - 340 Second Order Multiplexer	07
DMD - 4500/5000 Modulator Section	08

DMD - 4500/5000 Demodulator Section	09
RCU - 5000 M:N Switch	10
DMD15 Modulator	20
DMD15 Demodulator	21
DMD15 Modem	22
DVB3030 Video Modulator, DM240	23
Reserved for future equipment types	24 – 31

Note that multi - drop override ID 01 can be used interchangeably to broadcast a message to a DMD - 3000/4000 modem, a DMD - 4500/5000, a DMD15 modem, or a DVB3030. Radyne Inc. Corp. recommends that the multi - drop override IDs be issued only during system configuration as a bus test tool by experienced programmers, and that they not be included in run - time software. It is also advantageous to consider the use of multiple bus systems where warranted by a moderate to large equipment complement.

Therefore, if a DMD15 Modulator is queried for its equipment type identifier, it will return a "20" and DMD15 Demodulator will return a "21". A DMD15 Modem will also return an "22". A DVB3030 Video Modulator will return a "23."

4.5.6 Software Compatibility

The COMMSPEC, operating in conjunction within the RLLP shell, provides for full forward and backward software compatibility independent of the software version in use. New features are appended to the end of the DATA field without OPCODE changes. Older software simply discards the data as extraneous information without functional impairment for backward compatibility.

If new device-resident or M&C software receives a message related to an old software version, new information and processes are not damaged or affected by the omission of data.

The implementation of forward and backward software compatibility often, but not always, requires the addition of new Opcodes. Each new function requires a new Opcode assignment if forward and backward compatibility cannot be attained by other means.

When Radyne Inc. equipment is queried for bulk information (Query Mod, Query Demod, etc.) it responds by sending back two blocks of data; a Non-Volatile Section (parameters that can be modified by the user) and a Volatile Section (status information). It also returns a count value that indicates the size of the Non-Volatile Section. This count is used by M&C developers to index into the start of the Volatile Section.

When new features are added to Radyne Inc. equipment, the control parameters are appended to the end of the Non-Volatile Section, and status of the features, if any, are added at the end of the Volatile Section. If a remote M&C queries two pieces of Radyne Inc. equipment with different revision software, they may respond with two different sized packets. The remote M&C MUST make use of the non-volatile count value to index to the start of the Volatile Section. If the remote M&C is not aware of the newly added features to the Radyne Inc. product, it should disregard the parameters at the end of the Non-Volatile Section and index to the start of the Volatile Section.

If packets are handled in this fashion, there will also be backward-compatibility between Radyne Inc. equipment and M&C systems. Remote M&C systems need not be modified every time a feature is added unless the user needs access to that feature.

4.5.7 RLLP Summary

The RLLP is a simple send-and-wait protocol that automatically re-transmits a packet when an error is detected, or when an acknowledgment (response) packet is absent.

During transmission, the protocol wrapper surrounds the actual data to form information packets. Each transmitted packet is subject to time out and frame sequence control parameters, after which the packet sender waits for the receiver to convey its response. Once a receiver verifies that a packet sent to it is in the correct sequence relative to the previously received packet, it computes a local checksum on all information within the packet excluding the <SYN> character and the <CHECKSUM> fields. If this checksum matches the packet <CHECKSUM>, the receiver processes the packet and responds to the packet sender with a valid response (acknowledgment) packet.

The response packet is therefore either an acknowledgment that the message was received correctly. If the sender receives a valid acknowledgment (response) packet from the receiver, the <FSN> increments and the next packet is transmitted as required by the sender.

If an acknowledgment (response) packet is lost, corrupted, or not issued due to an error and is thereby not returned to the sender, the sender re-transmits the original information packet; but with the same <FSN>. When the intended receiver detects a duplicate packet, the packet is acknowledged with a response packet and internally discarded to preclude undesired repetitive executions. If the M&C computer sends a command packet and the corresponding response packet is lost due to a system or internal error, the computer times out and re-transmits the same command packet with the same <FSN> to the same receiver and waits once again for an acknowledgment.

Refer to Appendix A for RLLP.

4.6 Simple Network Management Protocol (SNMP)

Simple Network Management Protocol (SNMP), as its name suggests, is a relatively simple protocol by which management information for a network device may be inspected and/or altered by remote administrators.

4.7 The Management Information Base (MIB)

Management objects are defined in the Management Information Base (MIB), which uses a hierarchical naming scheme. Within this scheme, each object is identified by an Object Identifier (OID), a sequence of non-negative integers that uniquely describes the path taken through the hierarchical structure.

MIB objects may then be specified either from the Root (which has no designator), or alternatively from anywhere within the hierarchical structure.

For example: 1.3.6.1.4.1.2591.4 is equivalent to {iso(1). org(3). dod(6). internet(1). private(4). enterprises(1). Radyne(2591). RCS10L(4)} (See Figure 1).

In general, we are mainly concerned with just two groups that reside in the *internet* subtree, namely the *mgmt*, and *private* groups. For completeness however, the four major groups are discussed below:

4.8 Directory {internet 1} 1.3.6.1.1

This area was reserved to describe how the OSI directory structure may be used in the Internet. To date this has not been implemented and therefore is of little interest to us.

4.9 Mgmt {internet 2} 1.3.6.1.2

This area was reserved to describe objects in the standard MIB. As RFCs defining new groups are ratified, the Internet Assigned Numbers Authority (IANA) assigns new group IDs.

4.10 Experimental {internet 3} 1.3.6.1.3

This subtree provides an area where experimentation is carried out. Only those organizations directly involved in the experiment have any interest in this subtree.

4.11 Private {internet 4} 1.3.6.1.4

This is possibly the most important area of the MIB, since it is within this subtree that vendors place objects specific to their particular devices. Beneath the private branch, there is a subtree called enterprises, beneath which each vendor may define its own structure. Vendors are assigned Private Enterprise Numbers (PENs) that uniquely identify them. They may then place all objects specific to their devices in this tree, provided of course that the object conforms to the format defined by SMI. Radyne Inc.'s Private Enterprise Number is 2591. Other products are added to Radyne Inc.'s subtree as they become remotely manageable through SNMP.

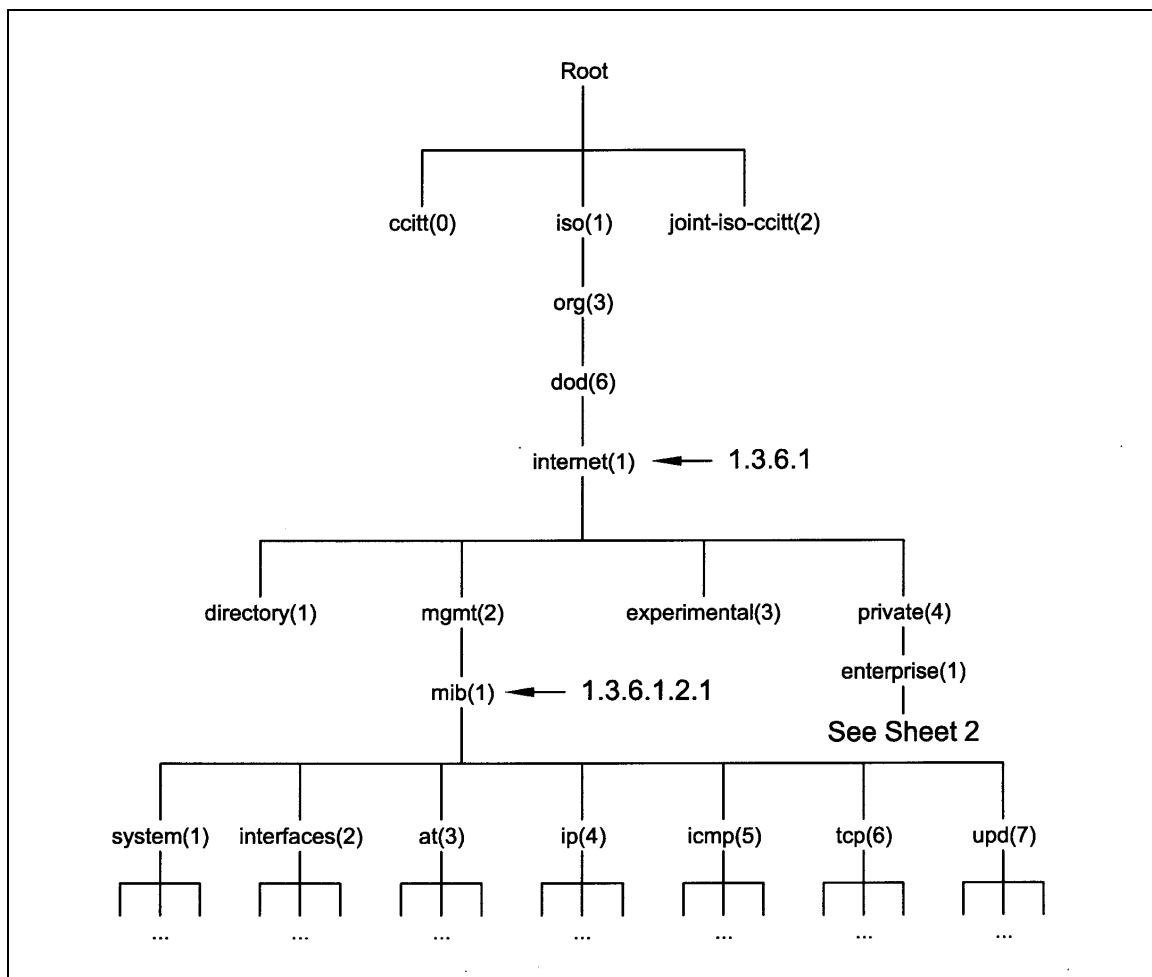

Figure 1. Object Identifiers in the Management Information Base (Sheet 1 of 2)

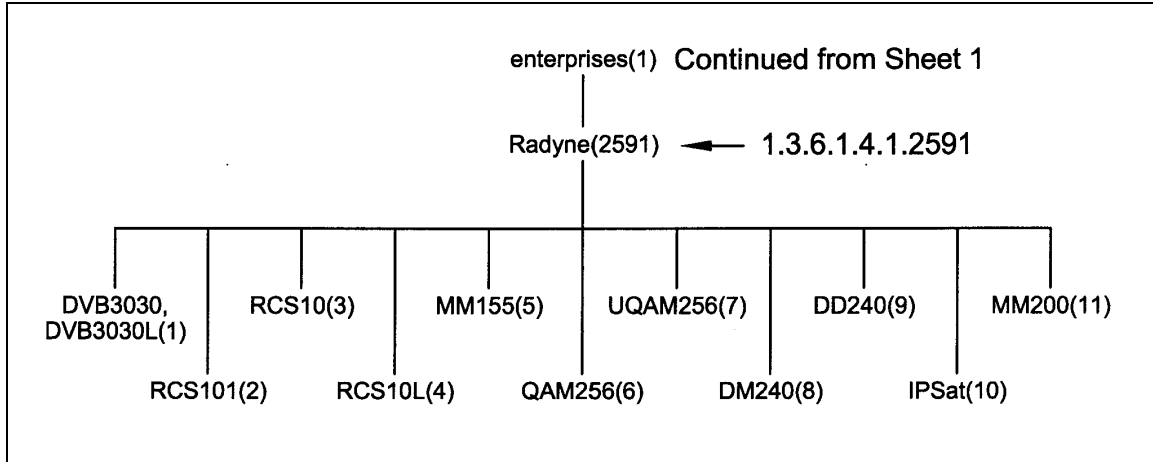

Figure 1. Object Identifiers in the Management Information Base (Sheet 2 of 2)

Refer to Appendix B for MIB listing.

4.12 Terminal Port User Interface

The Terminal Port of the MM200 allows for complete control and monitoring of all MM200 parameters and functions via an RS-232 Serial Interface. Terminal Mode' can be entered from the front panel by selecting 'System' and then 'Control Mode' followed by 'Terminal.' The default settings for the terminal are as follows:

19,200 Baud; 8 Data bits; 1 stop bit; No parity

The baud rate can be changed at the front panel by using the *System>Baud Rate* Menu. The new baud rate does not take effect until power to the unit has been shut down and turned back on again.

The Terminal Control Mode is menu-driven and the allowable values for each item number will be shown. To change an item, type in its number followed by <ENTER>. If the parameter to be changed requires a numeric value, enter the number followed by <ENTER>. If the parameter is non-numeric, press <SPACE> to cycle through the list of available entries. Note that the items that do not have ID numbers are Status only and cannot be changed.

4.13 Modem Configuration

4.14 Connecting the Terminal

1. Connect the computer to the MM200 Terminal Connector (J2) on the rear of the unit using the RS-232 Cable (Figure 1).

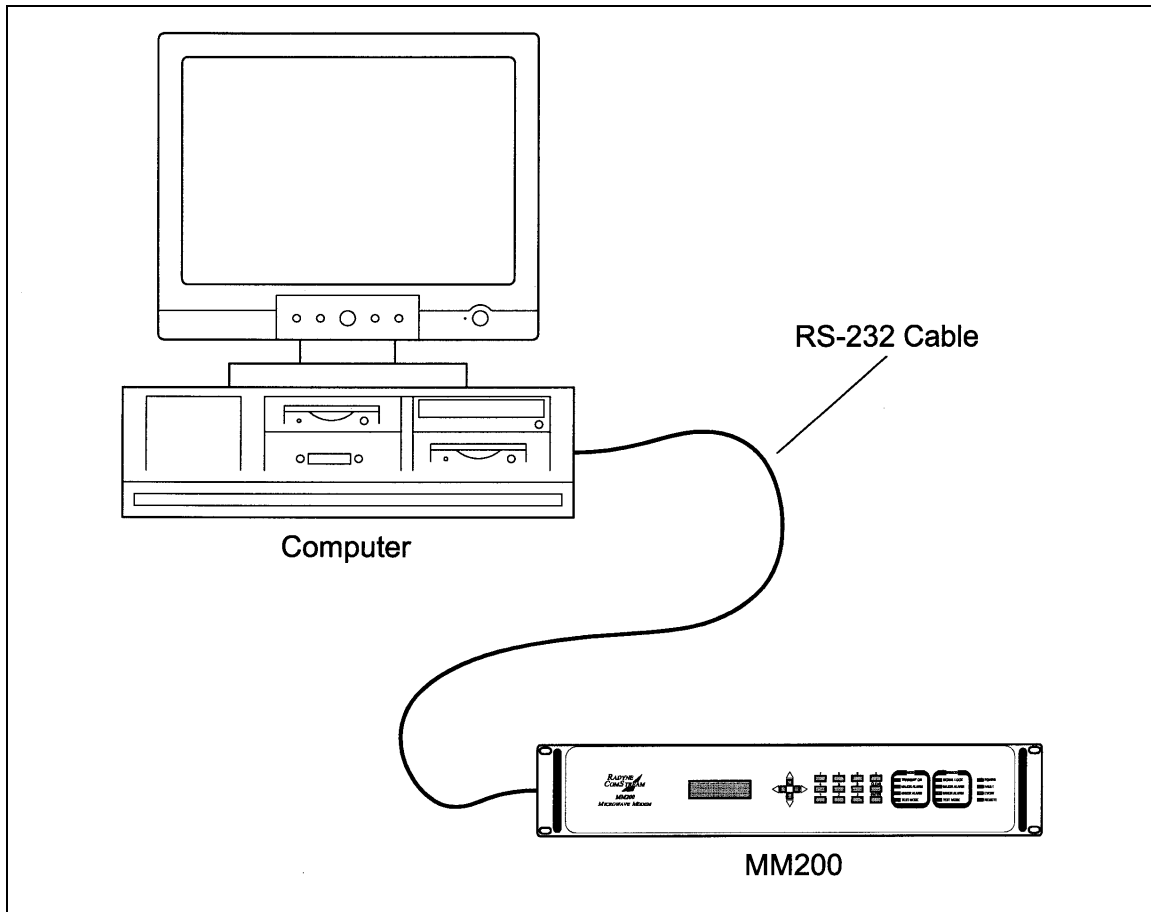

Figure 1.

1. Verify that your emulation software is set to the following:

VT100
9600 baud
8 data bits
no parity
1 stop bit

Modify the MM200 selection, if necessary, to match the settings (the Front Panel 'SYSTEM' Sub-Menu contains all the Terminal Emulation Controls).

2. If the system is set up properly and the terminal fails to come up, verify that the Terminal Cable (CA/3448-6) is attached properly from the Back Plate (J2) to the Header (J9) on the Main M&C Card (AS/4458).

3. Switch S3 settings should be set as follows:

SW1:	On
SW2:	On
SW3:	Off
SW4:	Off

4.15 SNMP Option

- From the Main Menu, select '20' for Network Configuration. Verify that Selection 30, SNMP Option is enabled. The MM200 SNMP Option is enabled at the factory if purchased by the user. Please contact the Radyne Inc. Customer Service Department if the SNMP feature is not available.

4.16 Network Configuration

4.17 Terminal Screens

- The Network Configuration Screen is accessed from the MM200 Terminal top-level menu, selection #20. There are two available setup screens: SNMP and Security. Once logged on, the user can toggle back and forth using Selection Number 12, 'SNMP/Security'.

SNMP Controls Screen:

```

1.Main Menu
2.Control Mode :      TERMINAL      12.SNMP/Security
3.Term Emulate  :      VT 100      13.Logon
4.Term Baud    :      9600        14.Logoff

SETUP                STATUS
5.TrapType       :      VERSION2    Logon User       :      Oper-md5
6.PrimaryTrapHost:      192.168.0.25 Context Engine ID :      80000A1F01AC1264B0
7.SndaryTrapHost :      192.168.0.26 Engine Status    :      NORMAL
8.Trace Mode    :      LEVEL 5
9.Community     :      public

----- SNMP CONTROLS -----
30.SNMP Option  :      ENABLE
31.Boot Mode   :      NONVOL
32.Modem EthAddr :      :      0010650D03E8
33.Modem IPAddr :      192.168.0.243
34.Server EthAddr :      000000000000
35.Server IPAddr :      192.168.0.50

37.Router IPAddr :      192.168.0.254
38.IPAddressMask:      255.255.0.0

Enter Selection Number:

```

Security Controls Screen:

1.Main Menu				
2.Control Mode	:	TERMINAL	12.SNMP/Security	
3.Term Emulate	:	VT 100	13.Logon	
4.Term Baud	:	9600	14.Logoff	
SETUP		STATUS		
5.TrapType	:	VERSION2	Logon User	:
6.PrimaryTrapHost:		192.168.0.25	Context Engine ID	:
7.SndaryTrapHost	:	192.168.0.26	Engine Status	:
8.Trace Mode	:	LEVEL 5		
9.Community	:	public		
-----SECURITY CONTROLS-----				
10.SNMP V1&2 Access View:		adminVIEWadminACCESS		
11.Key Generation Mode	:	STORE		
12.Change Logon Password				
13.Change Authentication Password				
14.Change Privacy Password				
Enter Selection Number:				

- The SNMP Configuration can be monitored and controlled via a full screen presentation of current settings and status. The <Esc> Key redraws the entire screen and aborts input any time. The Spacebar refreshes the status area and is used to scroll through selection when in user input mode.
- To modify an item, the user simply presses its terminal selection followed by <Enter>. The modem responds by presenting the options available and requesting input. If the input is multiple choices, the user is prompted to use the Spacebar to scroll to the desired selection and then press <Enter>. An input can be aborted at any time by pressing <Esc>. Invalid input keys cause an error message to be displayed on the terminal. Some input or display status only appears when the user has the right access levels.

4.18 Logging on and Passwords

There are several available logon users each setup with a default password. The user must be logged on in order to view or change some settings. There are 3 levels of access rights in the MM200. These are:

Initial Access:	The default when no user is logged on.
Viewer Access:	Allows its user to modify its own logon and authentication passwords.
Operator Access:	All other SNMP and security selections can only be accessed.

Listed in the table below are the available user names and corresponding default passwords:

Security User	Logon Password	Authentication Password	Privacy Password
Initial			
Viewer	Viewer	Viewer	
Oper-md5	Oper	Oper	Oper
Viewer-sha	Viewer	Viewer	
Oper-sha	Oper	Oper	Oper

Note: All entries are case sensitive

4.19 Exiting SNMP Configuration

1. Select the Main Menu by pressing '1' followed by <Enter>, to go back to the MM200 top-level menu screen.

4.20 Logging On

1. The user must be logged on to have access to SNMP Features. To log on the SNMP configuration, press '13' followed by <Enter> to open the Logon Dialog Box.

```

+-----| Logon |-----+
|
| 1.User ID      :
| 2.Password    :
|
| 3.OK   4.CANCEL
|
+-----+

```

2. In the User ID Text Box, enter "Oper-md5" (case sensitive).
3. In the Password Text Box, enter "Oper" (case sensitive).
4. Select OK

4.21 Changing the Logon Password

To change the password, logged on so that the "SNMP/Security" selection appears. Once logged on, proceed to the "SECURITY CONTROLS" Menu Selections by pressing '12'. Press '12' again followed by <Enter> to open the Change Password dialog.

```

+-----| Change Password |-----+
|
| 1.Old Password :
| 2.New Password :
| 3.Re-enter New Password :
|
| 4.OK   5.CANCEL
|
+-----+

```

1. In the Old Password Text Box, enter "Oper" (case sensitive).

2. In the New Password Text Box, enter the new password (case sensitive, only *'s appear for security).
3. Re-enter the new password to verify the desired setting.
4. Select OK

4.22 Logging Off

1. To log off the SNMP Configuration, press '14' followed by <Enter>. The following confirmation message will be displayed to avoid inadvertent exits:

You will be logged off. Are you sure? (Y/N):

4.23 Changing Your Authentication Password

1. To change your authentication password, you must be logged on in order for the "SNMP/Security" selection to appear. Once logged on, proceed to the "SECURITY CONTROLS" Menu Selections by pressing '12', then '13', followed by <Enter> to open the Change Password Dialog.

```
+-----| Change Password |-----+
|                                     |
| 1.Old Password   :                 |
| 2.New Password   :                 |
| 3.Re-enter New Password :         |
|                                     |
| 4.OK           5.CANCEL            |
|                                     |
+-----+-----+-----+-----+
```

2. In the Old Password Text Box, enter "Oper" (case sensitive).
3. In the New Password Text Box, enter the new password (case sensitive, only *'s appear for security).
4. Re-enter the new password to verify desired setting.
5. Select OK

4.24 Changing Your Privacy Password

To change your privacy password, you must be logged on as either Oper-md5 or Oper-sha (Operator). Once logged on, proceed to the "SECURITY CONTROLS" menu selections by pressing 12. Press 14 followed by <Enter> to open the Change Password dialog.

```
+-----| Change Password |-----+
|                                     |
| 1.Old Password   :                 |
| 2.New Password   :                 |
| 3.Re-enter New Password :         |
|                                     |
| 4.OK           5.CANCEL            |
|                                     |
+-----+-----+-----+-----+
```

1. In the Old Password Text Box, enter "Oper" (case sensitive).
2. In the New Password Text Box, enter the new password (case sensitive, only *'s appear for security).

3. Re-enter the new password to verify desired setting.
4. Select OK

4.25 Modem MM200 High-Speed Microwave Modem Ethernet Address

1. The Modem MM200 High-Speed Microwave Modem Ethernet Address is configured at the factory. It is a unique Radyne Inc. equipment identifier.

Example: 0010650903EB



4.26 Modem IP Address

1. Select 33, 'Modem IP Addr'. Enter the Modem Internet Address in dot notation and press <Enter>. Please consult your network administrator for valid addresses.

Example - 192.168.0.35

2. The IP Address that is selected will be used for the Ethernet Test that follows.

4.27 Server Ethernet Address

This section refers to the boot host.

1. Select 34, 'Server Eth Addr'. Enter the Server 12 Digit Ethernet Address and press <Enter>. Zero out this address if not known at this time. The system will resolve it dynamically at run time.

Example: 0FD0640203ED or 000000000000

4.28 Server IP Address

This section refers to the Host that will be used to optionally boot the MM200 on power-up. The host should be acceptable to the transport layer. In other words, the transport layer needs to be able to open a connection to the entity specified by the server IP Address field.

1. Select 35, 'Server IP Addr'. Enter the Server Internet Address in dot notation and press <Enter>. Please consult your network administrator for valid addresses.

Example: 192.168.0.50

2. The IP Address that is selected will be used for the Ethernet Test that follows.

4.29 Server Host Name

This section refers to the Boot Host.

1. Select 36, 'Server Host Name'. Enter the Server Host Name and press <Enter>. This is a descriptive entry only.

Example: SERVER

4.30 Router IP Address

Select 37, 'Router IP Addr'. Enter the router Internet Address in dot notation and press <Enter>. Please consult your network administrator for valid addresses.

Example: 192.168.0.254

4.31 IP Address Mask

In the mask (more clearly seen in the binary format), binary 1s indicate the position of the network and subnet portion of the IP Address while binary 0s identify bits that represent the individual interfaces. To recognize a subnet, each system in the subnet must have the same subnet mask. Please consult your network administrator for a valid address class mask.

1. Select 38, 'IP Address Mask'. Enter the IP Address mask in dot notation and press <Enter>.

Example: 255.255.0.0

4.32 Boot Mode (Optional)

1. Select '31' from the Controls Menu and press <Enter>. Scroll through the various selections to 'NVBOOT' and press <Enter>. The above settings will be enabled the next time the system is rebooted. If a bootp server is available, the MM200 can be remotely configured by selecting bootp mode. This option is currently not available.

4.33 Community

Each managed station controls its own local MIB and must be able to control the use of that MIB by a number of management stations. This relates to security concerns. A managed MIB such as the MM200 needs to protect itself from unwanted and unauthorized access. SNMP, as defined in RFC 1157, provides only a limited capability for such security, namely the concept of a community. An SNMP Community is the relationship between an SNMP Agent and Management Stations.

1. To set the community string on the MM200, select 9, 'Community'. Enter the desired community name and press <Enter>.

Example: "public"

4.34 Trap Type and Trap Hosts

Traps enable the modem to notify the management station of significant events such as alarms. Version1 and version2 Traps are supported at this time. These are Operator selectable using Terminal Command Number 5. The messages are sent to specific pre-defined hosts. The Primary and Secondary Trap Hosts IP Addresses are setup using Terminal Commands 6 and 7. Each host should be acceptable to the transport layer. In other words, the transport layer needs to be able to open a connection to the entities specified by the trap host fields.

4.35 Trace Mode

1. For debugging purposes, a trace mode is specified by the Operator users for various diagnostic levels.

4.36 SNMP V1 & 2 Access View

The default access rights for Version 1 and 2 SNMP users are minimal. They are limited to a system view, and a description of the MM200 System and Contact Information. For additional information go to View-Based Access Control Section). To accommodate older systems, an Operator user may modify these access rights to allow full or partial read/write access. SNMP Version 1 and 2 does not use any security measures, therefore users should be extra careful when changing access rights.

4.37 Key Generation Mode

The password localization algorithm is intensive enough that the Motorola 68332 Embedded Processor cannot handle the process in a timely manner. This selection allows the Operator user to optionally store localized keys in non-volatile memory. These keys correspond to a set of passwords and Modem IP Address. If either changes, the SNMP agent automatically recalculates the new keys and stores them in non-volatile memory (only if the Key Generation Mode is set to 'STORE').

4.38 Context Engine ID

"contextEngineID" is the unique identifier of the MM200 SNMP Engine that provides services for sending and receiving messages, authenticating and encrypting messages, and controlling access to managed objects.

1. The Context Engine ID, 80000A1F01AC1264B0, is formatted as follows:
 - a. The first 4 bytes are the Radyne Inc. Private Enterprise Number (2591).
 - b. The very first bit is set to 1, for example: 80000A1F (H).
 - c. The fifth byte indicates how the 6th and remaining bytes are formatted. A '1' means it's an IPv4 Address.
 - d. The last 4 bytes are the IP Address 172.18.100.176 (AC1264B0).

4.39 View-Based Access Control

SNMPv3 defines a method of access control known as the View-based Access Control Model (VACM). It is defined as a means to restrict access to particular subsets of variables based on the identity of the manager and the security level used in the request.

A view is a group of MIB variables on the agent. The agent defines a view for each user based on the user identity (securityName) and security level. Following are the major views:

System view: Access to system description

MIB-II view: Access to the standard MIB-II information

Device view: Access to the device private information

World view: Access to every managed object in the MIB

Following are the available access groups:

Group	Context/Community	Security Level	Read Access	Write Access
NULL	mib2	NoAuth/noPriv	System view	NONE
Viewer	mib2	Auth/noPriv	MIB-II view	NONE
Viewer	Dev	Auth/Priv	Device view	NONE
Oper	mib2	Auth/noPriv	MIB-II view	MIB-II view
Oper	Dev	Auth/Priv	Device view	Device view

The NULL Security Name is for backward compatibility with SNMP Version 1 and 2 management stations (security names are not defined for earlier protocols). In this case, the contextName in each view may refer to either a contextName or a communityName. The securityLevel would then be noAuth/noPriv.

4.40 Verification

4.41 Connect the Ethernet Cable

1. Connect the computer to the MM200 Ethernet port using the RJ-45 to RJ-45 10BaseT Cables via a hub as shown below.

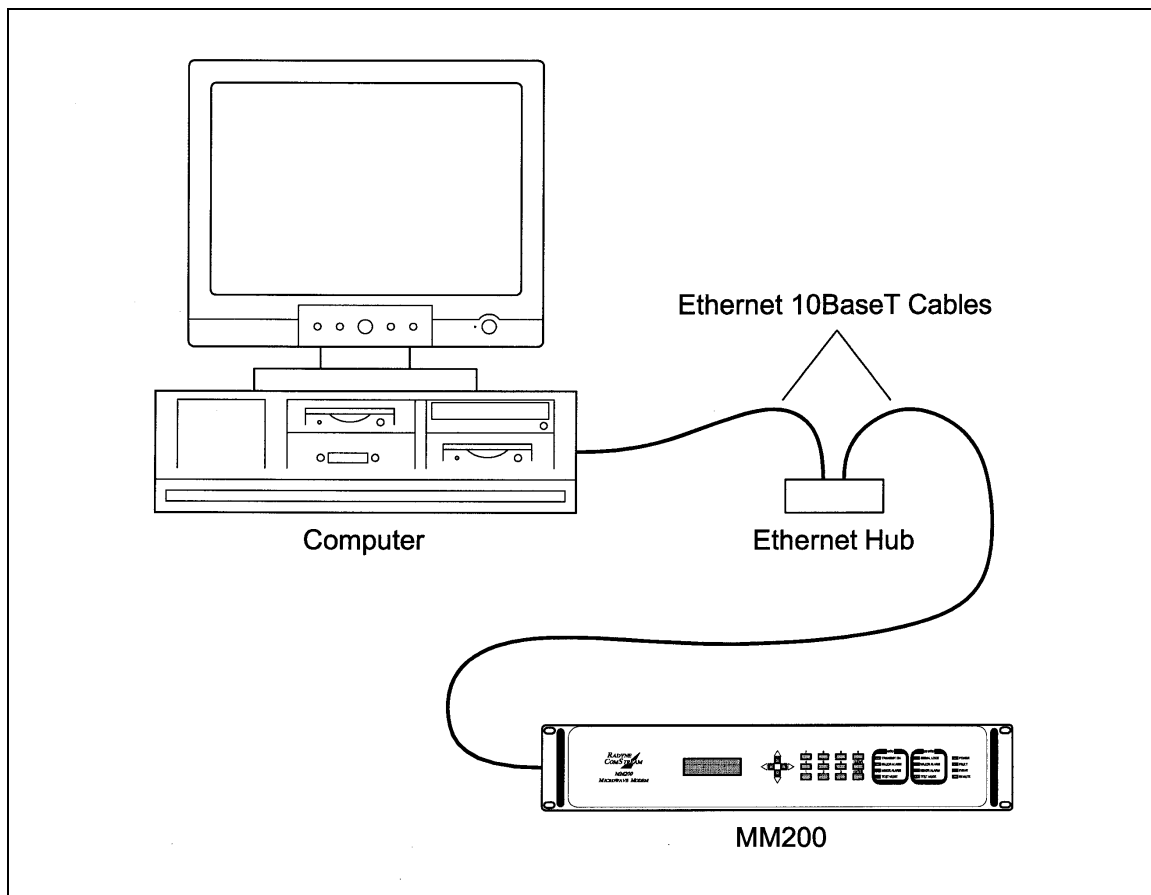

Figure 2.

4.42 Ping Program

1. PING is an application that uses the ICMP protocol to report if a host is responding. To check whether the MM200 modem is reachable, use the PING program installed on your computer along with the modem IP Address set in section 3.2.3.

Example: ping 192.168.0.35

2. If everything is functioning correctly, replies from the modem will appear on the computer screen along with the time it took to respond. If unsuccessful, verify the following:
 - a. The cables are secured.
 - b. The Link Light is illuminated.
 - c. The IP Address that is used matches the Modem's IP Address.
 - d. The Server and Modem are on the same subnet.

4.43 SNMP Test

1. Once it is determined that the MM200 is reachable, compile the custom Management Information Base (MIB) for use by the Network Management Station (NMS). The MIB uses a hierarchical naming scheme. Each managed object in the MM200 is identified by an Object Identifier (OID), a sequence of non-negative integers that uniquely describes the path taken through the hierarchical structure.
2. Using the modem IP Address, perform a Walk of the MIB to retrieve all the MIB objects managed in the MM200.



Electrical Interfaces

5

5.0 MM200 Connections

All MM200 connections are made to labeled connectors, and to any optional interfaces installed in slots located on the rear of the unit. Any connection interfacing to the MM200 must be the appropriate mating connector. Refer to Figure 5-1 and Figures 5-3 through 5-6 for connector locations.

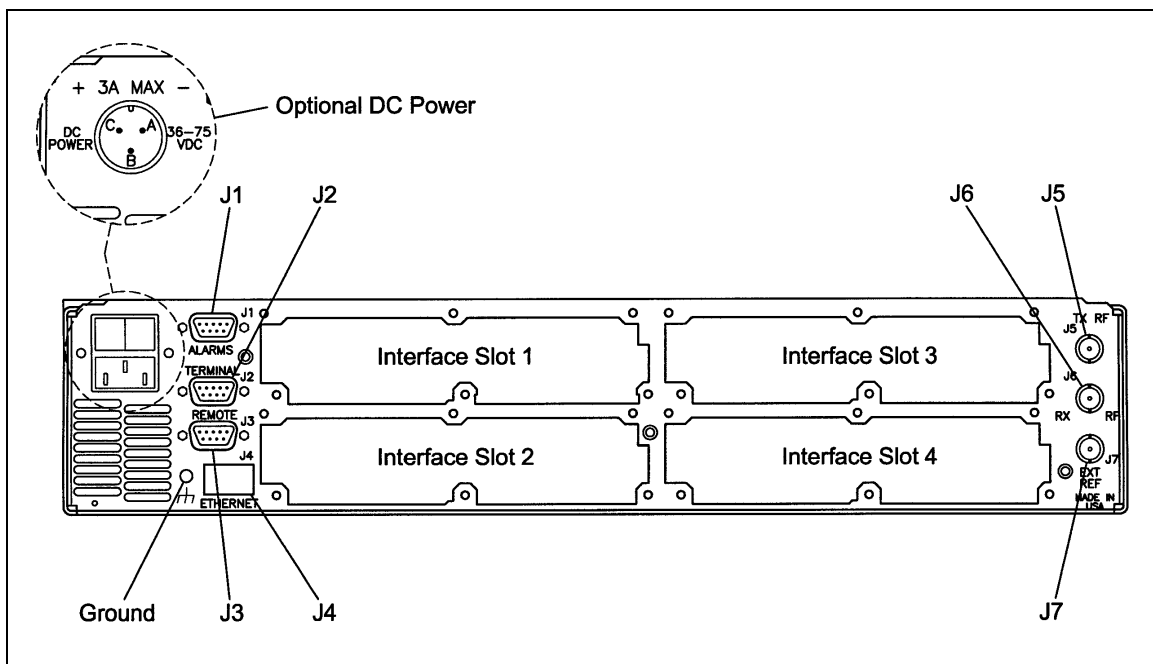

Figure 5-1. MM200 Rear Panel Connector and Optional Interface Slots

5.1 Power

5.1.1 AC Power

The unit is powered from a 100 – 240 VAC, 50 – 60 Hz source. Maximum unit power consumption is 110 W. The switch turns power on and off to the unit. A chassis ground connection can be made at the #10-32 threaded stud located to the lower right of the AC Power Connector.

5.1.2 DC Power

The chassis can be factory optioned for 48 or 24 VDC prime power.

Power Requirements:

48 VDC Option: 3 A maximum, 36 - 75 VDC

24 VDC Option 6 A maximum, 19 - 36 VDC

Refer to Table 5-1 below for pinouts for optional DC Power plug.

Table 5-1. DC Power	
A	- DC Input
B	Ground
C	+ DC Input

5.2 Alarm Port

The Alarm Connector (J1) is used to indicate the fault condition of the modulator to external equipment. This male 9-Pin D-Sub Connector provides connection to two form-c relays and an open collector output for mod and demod. The user can distinguish between modulator and demodulator alarms with the relays. All minor alarms are ignored. A major or common fault will activate the alarm. Refer to Table 5-2 for connector pinouts. Table 5-3 below describes the alarm indications.

Table 5-2. Alarm Connector J6 Pin Assignment	
Pin No.	Connection
1	Mod (Open Collector)
2	Mod (Normally Closed)
3	Demod (Open Collector)
4	Demod (Normally Closed)
5	Ground
6	Mod C
7	Mod (Normally Open)
8	Demod C
9	Demod (Normally Open)

Table 5-3. Alarm Indications	
Alarm	Pin Description
None	6 – 7 shorted, 8 – 9 shorted
Mod	6 – 2 shorted, 5 – 1 driven high
Demod	8 – 4 shorted, 5 – 3 driven high

5.3 Terminal Port (I/O)

The Terminal Port (J2) can be used for the monitor & control functions of the unit. The physical interface is a female 9-Pin D-Sub Connector. This bi-directional port complies with RS-232 Electrical Specifications. The pinouts are listed in Table 5-4a and 5-4b. S3 can be found on the M&C Card by removing the top cover.

Table 5-4a. J2 - RS-232 Terminal Port - 9-Pin 'D' Female S3 – Switch 1 & 2 Off, Switch 3 & 4 On			
Pin No.	Signal Name	Description	Direction
2	TxD	Transmit Data	Output
3	RxD	Receive Data	Input
5	GND	Ground	---

Table 5-4b. J2 - RS-232 Terminal Port - 9-Pin 'D' Female S3 – Switch 1 & 2 On, Switch 3 & 4 Off			
Pin No.	Signal Name	Description	Direction
2	RxD	Receive Data	Input
3	TxD	Transmit Data	Output
5	GND	Ground	---

5.4 Remote Port (I/O)

The Remote Port (J3) can be used for the monitor & control functions of the unit. The physical interface is a female 9-Pin D-Sub Connector. This bi-directional port complies with RS-485 Electrical Specifications. Pin-outs are listed in Table 5-5.

Table 5-5. J3 - RS-485 Remote Control - 9-Pin 'D' Female			
Pin No.	Signal	Description	Direction
1	Tx (B)	Transmit Data (+)	Output
5	GND	Ground	-
6	Tx (A)	Transmit Data (-)	Output
8	Rx (B)	Receive Data (+)	Input
9	Rx (A)	Receive Data (-)	Input

5.4.1 Remote Port Cabling for a Standard Computer RS-232 COM Port

A cable with the following pin-outs is used for Remote Port Communications.

Remote Port Cabling for a Standard Computer RS-232 COM Port - 9-Pin 'D' Male		
Computer End Pin No.	Signal	Modem End Pin No.
2	Tx (B)	6
3	Rx (B)	9
5	GND	5

If the MM200 does not have the option of changing from RS-232 to RS-422, an RS-232 to RS-422 Interface Converter is required. The RS-422 end is attached to the cable, the other is attached to the standard COM Port of the computer. A suggested converter is P/N K422-99 available from KK Systems, Ltd. (www.kksystems.com).

If communication is required to a Remote Port via an Overhead Interface, the following cabling is required (refer to Figure 5-2):

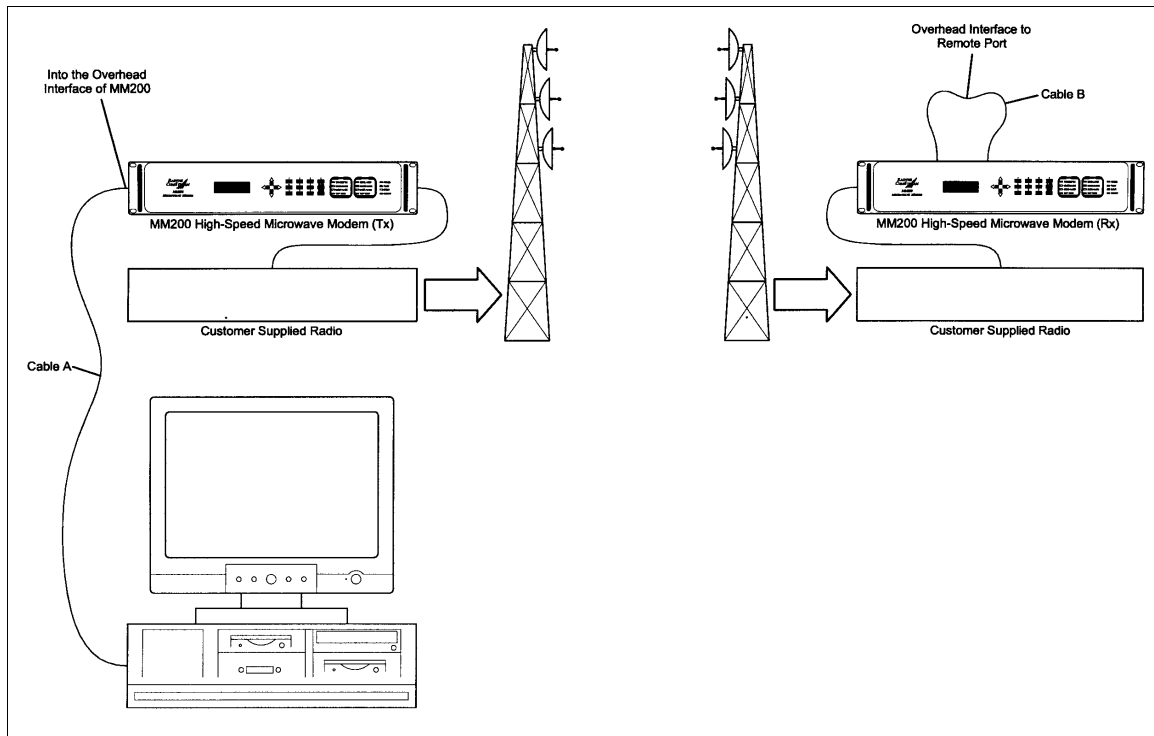

Figure 5-2. Standard Computer Cabling Block Diagram

From the Computer Remote Cable to the Overhead (Cable A)	
9-Pin 'D-Sub'	15-Pin HD

Female		'D-Sub' Male	
1	-TX	6	-TX
5	GND	2	GND

6	+TX	1	+TX
8	-RX	13	-RX
9	+TX	3	+TX
		7 to 12	+RX CLK to +TX CLK
		8 to 11	-RX CLK to -TX CLK

From the Overhead to the Remote Port of the Remote Modem (Cable B)	
9-Pin 'D-Sub'	15-Pin HD

Female		'D-Sub' Male	
6	-TX	6	-TX
5	GND	2	GND
1	+TX	1	+TX
9	-RX	13	-RX
8	+TX	3	+TX
		7 to 12	+RX CLK to +TX CLK
		8 to 11	-RX CLK to -TX CLK

5.5 Ethernet Interface (I/O)

The Ethernet Interface (J4) can be used for the monitor & control functions of the unit. The physical interface is a standard female RJ-45 Connector.

5.6 TX RF Port (Output)

The TX RF Port (J5) is used to transmit RF signals. The physical interface is a Female 750 Ω BNC Connector and has an output of 50 – 90 MHz IF.

5.7 RX RF Port (Input)

The RX RF Port (J6) is used to receive RF signals. The physical interface is a Female 750 Ω BNC Connector and has an output of 50 – 90 MHz IF.

5.8 External Reference (Input)

The External Reference Input (J7) is supplied to allow the customer to phase-lock the modulator's internal oscillator to an external reference.

This female BNC Connector accepts a 1.5 – 5 Vp-p @ 50 Ω . The frequency range of the external reference is 1 – 10 MHz in 8 kHz steps.

5.9 Interface Slots 1 Through 4

Several Rear Panel Interfaces are available to slide into the base chassis to suit individual need. The Overhead/DS0 Audio Rear Panel Interface fits only in Interface Slot 1 (the upper left slot as viewed from the rear) and any combination of the following fit into any of the other three interface slots to suit the users need (Figure 5-1):

- High-Speed G.703/DS3, E3, STS-1 Rear Panel Interface
- Overhead/DS0 Audio Rear Panel Interface
- Optical/OC3 STM-1 Rear Panel Interface
- ASI Rear Panel Interface
- Wayside G.703/T1, E1 Rear Panel Interface
- Parallel RS-422/DVB, M2P Rear Panel Interface
- Parallel LVDS/DVB, M2P Rear Panel Interface
- SMPTE/310M Rear Panel Interface

5.10 High-Speed G.703/DS3, E3, STS-1 Rear Panel Interface

The High-Speed G.703/DS3, E3, STS-1 Rear Panel Interface is shown in Figure 5-3. The connectors are listed below.

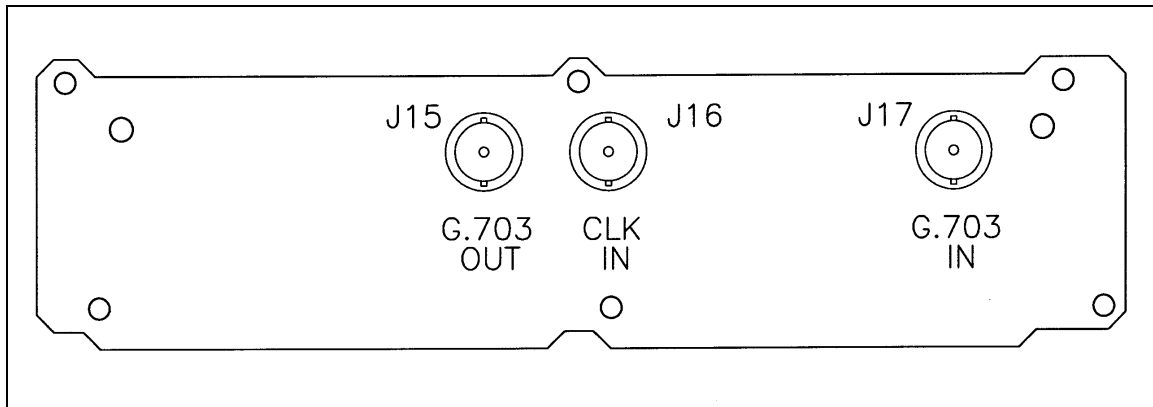

Figure 5-3. High-Speed G.703/DS3, E3, STS-1 Rear Panel Interface

5.10.1 G.703 OUT Female BNC Connector (J15)

Provides G.703 Data Output from the receiver.

5.10.2 CLK IN Female BNC Connector (J16)

Accepts External Buffer Clock input.

5.10.3 G.703 IN Female BNC Connector (J17)

Accepts G.703 Data Input to be transmitted.

5.11 Overhead/DS0 Audio Rear Panel Interface

This rear panel interface (Figure 5-4) provides eight 64 Kbps DS0 interfaces or seven DS0 and one Audio Channels. Refer to Tables 5-6 and 5-7 for pin assignments.

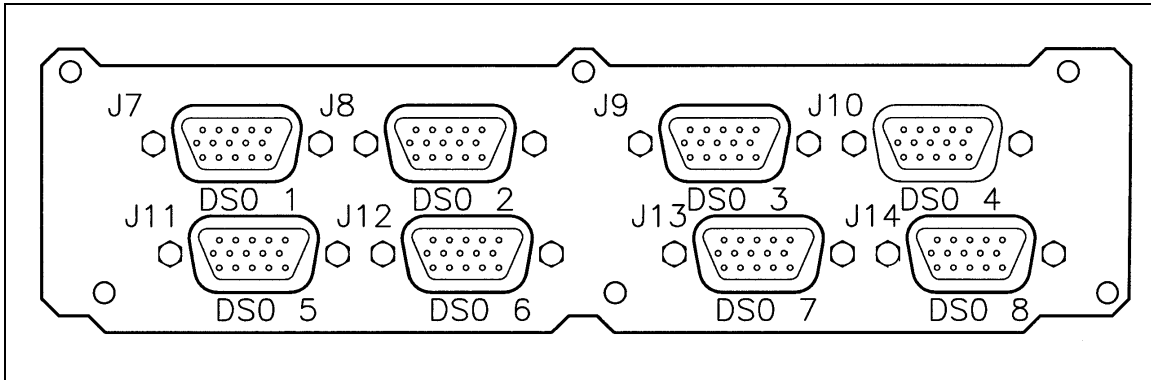

Figure 5-4. Overhead/DS0 Audio Rear Panel Interface

DS0			Audio	
Pin	Signal	Direction	Pin	Signal
1	RX_DS0 +	Out	1	
2	GND		2	
3	TX_DS0 +	In	3	PUSH_TT
4	REF_CLK +	Out	4	REF_CLK +
5	N/C		5	AUDIO_TX -
6	RX_DS0 -	Out	6	
7	RX_CLK +	Out	7	
8	TX_CLK -	In	8	
9	REF_CLK -	Out	9	REF_CLK -
10	N/C		10	AUDIO_RX +
11	RX_CLK -	Out	11	
12	TX_CLK +	In	12	
13	TX_DS0 -	In	13	PUSH_TT-GND
14	N/C		14	AUDIO_RX -
15	N/C		15	AUDIO_TX +

Table 5-7. Channels 2 – 8 (Female 15-pin HD ‘D-Sub’)		
DS0		
Pin	Signal	Direction
1	RX_DS0 +	Out
2	GND	
3	TX_DS0 +	In
4	REF_CLK +	Out
5	N/C	
6	RX_DS0 -	Out
7	RX_CLK +	Out
8	TX_CLK -	In
9	REF_CLK -	Out
10	N/C	
11	RX_CLK -	Out
12	TX_CLK +	In
13	TX_DS0 -	In
14	N/C	
15	N/C	

5.11.1 DS01 15-Pin Female HD ‘D’ Sub Connector (J7)

Provides Channel 1 DS0 or Audio Interface.

5.11.2 DS02 15-pin female HD ‘D’ sub connector (J8)

Provides Channel 2 DS0 Interface.

5.11.3 DS03 15-pin female HD ‘D’ sub connector (J9)

Provides Channel 3 DS0 Interface.

5.11.4 DS04 15-pin female HD ‘D’ sub connector (J10)

Provides Channel 4 DS0 Interface.

5.11.5 DS05 15-pin female HD ‘D’ sub connector (J11)

Provides Channel 5 DS0 Interface.

5.11.6 DS06 15-pin female HD ‘D’ sub connector (J12)

Provides Channel 6 DS0 Interface.

5.11.7 DS07 15-pin female HD 'D' sub connector (J13)

Provides Channel 7 DS0 Interface.

5.11.8 DS08 15-pin female HD 'D' sub connector (J14)

Provides Channel 8 DS0 Interface.

5.12 Optical/OC3 STM-1 Rear Panel Interface

This rear panel interface (Figure 5-5) provides OC3 Optical or STM1 Electrical Interface.

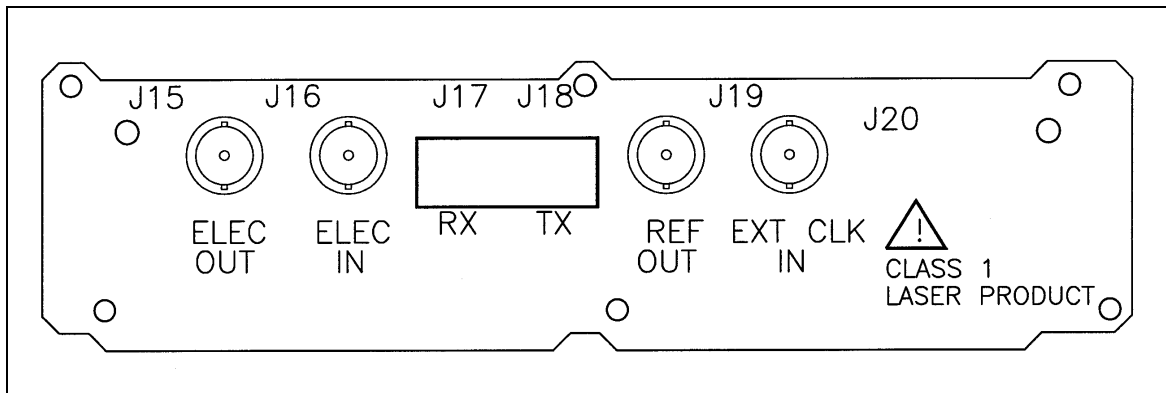

Figure 5-5. Optical/OC3 STM-1 Rear Panel Interface

5.12.1 ELEC OUT Female BNC Connector (J15)

Provides STM1 Data Output from the receiver.

5.12.2 ELEC IN Female BNC Connector (J16)

Accepts STM1 Data Input to be transmitted.

5.12.3 OPTICAL IN SC Connector (J17)

Accepts OC3 Data Input to be transmitted.

5.12.4 Optical Out SC Connector (J18)

Provides OC3 Data Output from the receiver.

5.12.5 REF OUT Female BNC Connector (Optional) (J19)

Provides Reference Clock Output.

5.12.6 REF IN Female BNC Connector (Optional) (J20)

Accepts the Reference Clock Input.

5.13 ASI Rear Panel Interface

This rear panel interface (Figure 5-6) provides Asynchronous Serial Interface (ASI).

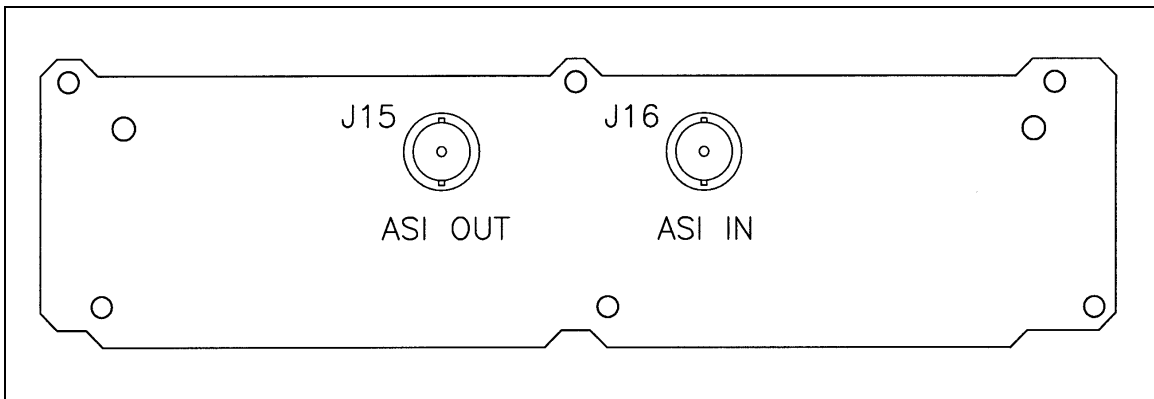

Figure 5-6. ASI Rear Panel Interface

5.13.1 ASI OUT Female BNC Connector (J15)

Provides ASI Data Output from the receiver.

5.13.2 ASI IN Female BNC Connector (J16)

Accepts ASI Input to be transmitted.

5.14 Wayside G.703/T1, E1 Rear Panel Interface

This rear panel interface (Figure 5-7) provides T1 or E1 Data.

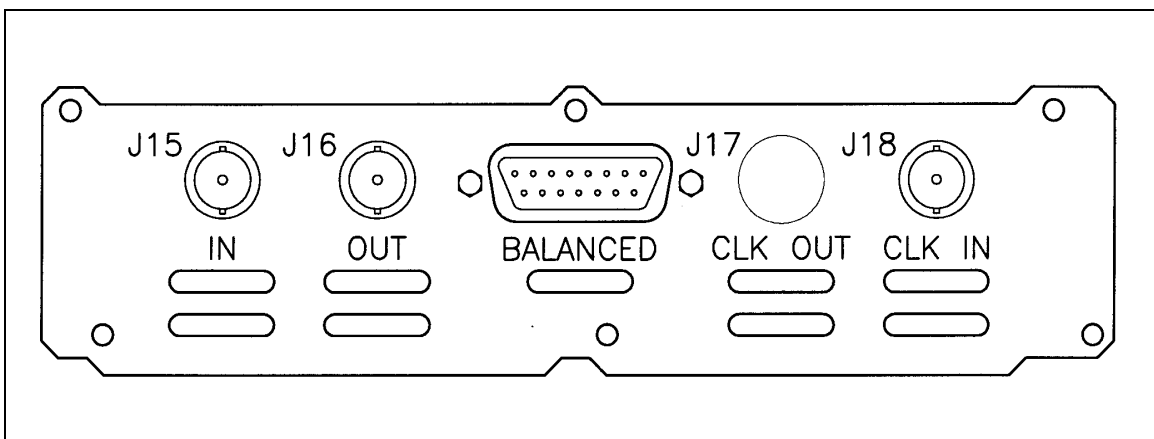

Figure 5-7. Wayside G.703/T1, E1 Rear Panel Interface

5.14.1 IN Female BNC Connector (J15)

Accepts E1 Data Input to be transmitted.

5.14.2 OUT Female BNC Connector (J16)

Provides E1 Data Output from the receiver.

5.14.3 BALANCED 15-pin female 'D' sub connector

Provides T1 Data Input and Output at the following pinouts:

Table 5-8. Balanced 15 Pin Female 'D' Sub Connector		
Pin No.	Signal	Direction
1	SD-A	In To Modem
9	SD-B	In to Modem
3	RD-A	Out From Modem
11	RD-B	Out From Modem
2,4	GND	Ground

5.14.4 CLK OUT (J17)

Not Used

5.14.5 CLK IN Female BNC Connector (J18)

Accepts the Reference Clock Input.

5.15 Parallel RS-422/DVB, M2P

This rear panel interface (Figure 5-8) provides DVB or M2P via a Front Panel selection. It can be ordered with RS-422 or LVDS Levels.

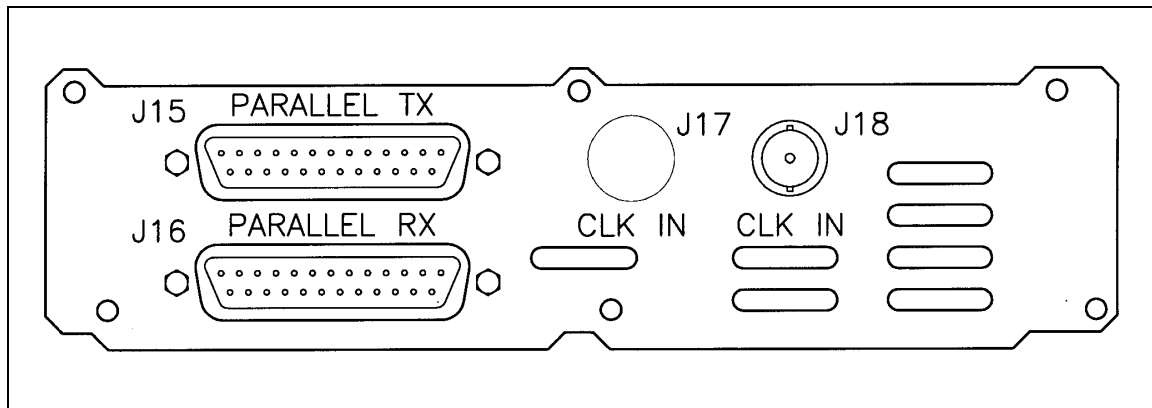

Figure 5-8. Parallel RS-422/DVB, M2P and Parallel LVDS/DVB, M2P

5.15.1 PARALLEL TX 25-pin female 'D' sub connector (J15)

Provides RS-422/LVDS DVB Demodulator Output.

Table 5-9. Parallel Tx RS-422/DVDS, DVB – 25-Pin Female 'D' Sub Connector		
Pin Number	DVB Signal	J15
1	CLK+	Output
14	CLK-	Output
2	SYSTEM GND	Output
15	SYSTEM GND	Output
3	D7+	Output
16	D7-	Output
4	D6+	Output
17	D6-	Output
5	D5+	Output
18	D5-	Output
6	D4+	Output
19	D4-	Output
7	D3+	Output
20	D3-	Output
8	D2+	Output
21	D2-	Output
9	D1+	Output
22	D1-	Output
10	D0+	Output
23	D0-	Output
11	DVALID+	Output
24	DVALID-	Output
12	PSYNC+	Output
25	PSYNC-	Output
13	Cable Shield	---

5.15.2 PARALLEL RX 25-pin female 'D' sub connector (J16)

Accepts RS-422/LVDS DVB Modulator Input.

Table 5-10. Parallel Rx RS-422/LVDS, DVB – 25-Pin Female 'D' Sub Connector		
Pin Number	DVB Signal	Direction
1	CLK+	Input
14	CLK-	Input
2	SYSTEM GND	Input
15	SYSTEM GND	Input
3	D7+	Input
16	D7-	Input
4	D6+	Input
17	D6-	Input
5	D5+	Input
18	D5-	Input
6	D4+	Input
19	D4-	Input
7	D3+	Input
20	D3-	Input
8	D2+	Input
21	D2-	Input
9	D1+	Input
22	D1-	Input
10	D0+	Input
23	D0-	Input
11	DVALID+	Input
24	DVALID-	Input
12	PSYNC+	Input
25	PSYNC-	Input
13	Cable Shield	---

5.15.3 CLK IN (J17)

Not Used

5.15.4 CLK IN Female BNC Connector (J18)

Accepts the Reference Clock Input.

5.16 Parallel LVDS/DVB, M2P

This rear panel interface provides Parallel RS-422/LVDS M2P Data.

5.16.1 PARALLEL TX 25-pin female 'D' sub connector (J15)

Provides RS-422/LVDS M2P Demodulator Output.

Table 5-11. Parallel Tx RS-422/LVDS, M2P – 25-Pin Female 'D' Sub Connector		
Pin Number	M2P Signal	Direction
1	NC	Output
14	NC	Output
2	CLK+	Output
15	CLK-	Output
3	SYNC+	Output
16	SYNC-	Output
4	VALID+	Output
17	VALID-	Output
5	D0+	Output
18	D0-	Output
6	D1+	Output
19	D1-	Output
7	D2+	Output
20	D2-	Output
8	D3+	Output
21	D3-	Output
9	D4+	Output
22	D4-	Output
10	D5+	Output
23	D5-	Output
11	D6+	Output
24	D6-	Output
12	D7+	Output
25	D7-	Output
13	Cable Shield	---

5.16.2 PARALLEL RX 25-pin female 'D' sub connector (J16)

Accepts RS-422/LVDS M2P Modulator Output.

Table 5-11. Parallel Rx RS-422/LVDS, M2P – 25-Pin Female 'D' Sub Connector		
Pin Number	M2P Signal	Direction
1	OUTCLK+	Output
14	OUTCLK-	Output
2	CLK+	Input
15	CLK-	Input
3	SYNC+	Input
16	SYNC-	Input
4	VALID+	Input
17	VALID-	Input
5	D0+	Input
18	D0-	Input
6	D1+	Input
19	D1-	Input
7	D2+	Input
20	D2-	Input
8	D3+	Input
21	D3-	Input
9	D4+	Input
22	D4-	Input
10	D5+	Input
23	D5-	Input
11	D6+	Input
24	D6-	Input
12	D7+	Input
25	D7-	Input
13	Cable Shield	---

5.16.3 CLK IN (J17)

Not Used

5.16.4 CLK IN Female BNC Connector (J18)

Accepts the Reference Clock Input.

5.17 SMPTE/310M Rear Panel Interface

This rear panel interface (Figure 5-9) provides SMPTE 310M Data.

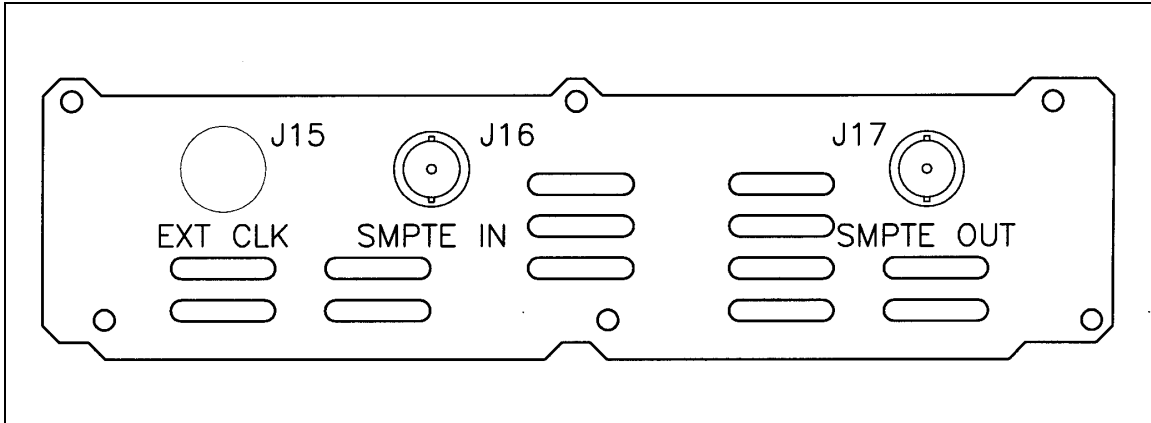

Figure 5-9. SMPTE/310M Rear Panel Interface

5.17.1 EXT CLK (J15)

Not Used

5.17.2 SMPTE IN Female BNC Connector (J16)

Accepts SMPTE 310M Data Input to be transmitted.

5.16.3 SMPTE OUT Female BNC Connector (J17)

Provides SMPTE 310M Data Output from the receiver.



Maintenance and Troubleshooting

6

6.0 Periodic Maintenance



CAUTION!!

*The MM200 contains a Lithium Battery. **DANGER OF EXPLOSION** exists if the battery is incorrectly replaced. Replace only with the same or equivalent type recommended by the manufacturer. Dispose of used batteries in accordance with manufacturers instructions.*

The MM200 modulator requires no periodic field maintenance procedures. Should a unit be suspected of a defect in field operations after all interface signals are verified, the correct procedure is to replace the unit with another known working MM200. If this does not cure the problem, wiring or power should be suspect.

There is no external fuse on the MM200. The fuse is located on the power supply assembly inside the case, and replacement is not intended in the field.

6.1 Maintenance Philosophy

The units Alarms, Monitors and Self Test functions will allow the operator to accurately diagnose if a problem exists within the MM200, or the signals coming to the MM200 from other equipment (including other MM200s). Additionally problems can be diagnosed to replaceable interfaces or the main MM200 chassis. Once a problem is believed to be with the MM200, it is expected that a replacement unit or interface will be used to prove where the fault lies. The faulty unit can then be sent to a Radyne Inc. repair center for repair. Please contact your Radyne Inc. Customer Service Center for return authorization and any special instructions.

6.2 Customer Service

Before calling your Customer Service representative with a question about your MM200, please obtain the following information:

1. The unit's serial number.
2. The main software number (listed on the Front Panel in the System Menu under HW/SW CONFIG).
3. The alarms that are triggered by the fault. These can be reviewed in the Current Alarms/Latched Alarms and the Events Menus. Refer to Sections 4.4.6, and 4.4.7 for more information on viewing these alarms.
4. All of the values shown in the Dmd Monitor Menu at the Receive Site.

Note: *If a terminal is available it is easier to view all these parameters on a terminal screen (SW Revisions 2.03 and above) See Section 4.7 for more information.*

6.3 Troubleshooting

Problem: Common Alarms "GLUE HW FPGA" or "TEST HW FPGA."

Actions: Replace the M&C Mux Card.

Problem: No demodulator lock

Actions:

1. Check the SNR and AGC of the demodulators. The SNR should be 33.0 or higher and the AGC should be between 200 and 600.
2. Verify that the modulator and the demodulator are set up correctly.
3. If a channel does not have the correct SNR or AGC, set the system's frequency plan to USER and check the frequency for each channel to verify that they match between the modulator and demodulator. Check the SNR and AGC again for correct readings.
4. If a channel is bad, set the demodulator's frequencies to the frequency that has the problem. If all the demodulator channels have bad SNR and AGC readings at the set frequency, the modulator channel that the frequency is set to is bad.
5. If all of the demodulator channels have good SNR and AGC except the original bad channel, that demodulator channel is bad.

Example: Channel 3 has low SNR and high AGC. The system's frequency plan is changed to USER. Check the frequency for each channel to verify that they match between the modulator and demodulator. Channel 3 still has low SNR and high AGC. Change the frequency of the demodulators to the frequency of Channel 3. If all of the demodulator channels have low SNR and high AGC, Channel 3 of the modulator is bad. If all the demodulator channels have good SNR and AGC except Channel 3, Channel 3 Demodulator is bad.

Problem: Bad Interface

Actions:

1. Verify that the system has RF Lock. If there is no RF Lock, check the modulator and demodulator for problems.
2. Check the setup of the interface (both transmit and receive).
3. If there is RF Lock, put the unit into Mux/Demux Loopback and check for data lock.
4. If no data lock, swap the interface for a known working interface.
5. If no data lock with known working interface, check the interface in a different slot.
6. If there is an interface problem or a modem interface slot problem, call the Radyne Inc. Customer Service Department.



Technical Specifications

7

7.0 Introduction

This section defines the technical performance parameters and specifications for the MM200 High-Speed Microwave Modem.

7.1 Specifications

Total Data Rate Variable from 1 to 200 Mbps total in 1 bps steps

Note *Interface selection may limit maximum data rate.*

Total Baud Rate	3.5 – 7, 7 – 14, 10.5 – 21, or 14 – 28 Mbaud depending upon number of IF channels installed
IF Channels	1 to 4
IF Channel Baud Rate	3.5 to 7 Mbaud Per Channel
Mux/Demux	One to four* data channel DVB compliant
Modulation	4, 16, 32, 64, 128, 256 QAM*
FEC	204/188 Reed Solomon
FEC/Mux Overhead	204/184 (204/188 for DVB Framed Interface)
Adaptive Equalizer	12 tap DFE and 8 tap FFE (One per IF Channel)
IF Range	50 to 90 MHz*
IF Return Loss	20 dB
Tx Output Power	0 to -25 dBm in 0.1 dB steps*
Spurious Output	-55 dBc in-band
Rx Input Power	0 to -25 dBm.
Frequency Stability	10 ppm
Carrier Acquisition	± 400 kHz or ± 10% of channel baud rate, whichever is less
Rx Data Buffer	0 to ± 2 Mbits
Remote Control	SNMP RS-485/-232 Modem Drives External Terminal
Chassis Size	2 RU (3.5")
Power	85 to 264 VAC, 50/60 Hz
Environmental	0 – 50° C
Compliance	CE mark

7.2 Options

-48 VDC
 Simplex Configuration, Modulator Only
 Simplex Configuration, Demodulator Only
 Space Diversity, Demodulator Only
 Additional Mod IF Channels. Up to 4 per Chassis
 Additional Demodulator IF Channels. Up to 4 per Chassis

7.3 Optional Data Interfaces

G.703 T3, E3 or STS-1*
DVB ASI (normal or advanced)
RS-422 Parallel, DVB Parallel, M2P*
LVDS Parallel, DVB Parallel, M2P*
OC3 Optical, STM1/ STS3 Electrical*
SMPTE
Other interfaces available upon request

Note: *Up to 4 interfaces per chassis. Any combination can be installed and operated by front panel control. Only one interface can be configured for DVB framed data.*

7.4 Optional Overhead Interfaces

Orderwire	Can be configured for eight DS0s or seven DS0s plus one Audio*
Wayside	T1 or E1*

* **Front panel selectable.**



Remote RLLP

A



CAUTION!!

When new features are added to Radyne equipment, the control parameters are appended to the end of the Non-Volatile Section of the Remote Communications Specification, and status of the features, if any, are added at the end of the Volatile Section. If a remote M&C queries two pieces of Radyne equipment with different revision software, they could respond with two different sized packets. The remote M&C **MUST** make use of the non-volatile count value to index to the start of the Volatile Section. If the remote M&C is not aware of the newly added features to the product, it should disregard the parameters at the end of the Non-Volatile Section and index to the start of the Volatile Section.

Before creating any software based on the information contained in this document, contact the Radyne Customer Service Department (602-437-9620) to find out if the software revision for that piece of equipment is current and that no new features have been added since the release of this document.

A.1 MM200 Opcode Command Set

The MM200 Opcode Command Set is listed below:

A.2 Modem Command Set

Command	Opcode	Description
Query Identification	0x2000	Returns Device ID
Query Control Mode	0x2001	Returns current MM200 control mode
Query Revision Number	0x2002	Returns software revision number
Query Firmware Part Number	0x2003	Return firmware part number and release date
Query Time	0x2004	Returns current time
Query Date	0x2005	Returns current date
Query Time and Date	0x2006	Returns current time and date
Query Current Summary Alarms	0x2010	Returns current summary alarms
Query Latched Summary Alarms	0x2011	Returns latched summary alarms
Query Common Configuration	0x203E	Query the MM200 for the common

		configuration
Query Mod Tx Enable	0x2054	Returns the carrier enable status
Query Mod Tx Carrier	0x2055	Returns the carrier mode
Query Mod Channel Status	0x2070	Query selected modulator channel status
Query Mod Channel Configuration	0x2071	Query selected modulator channel configuration
Query Mod Channel Config & Status	0x2072	Query selected mod channel config and status
Query Mod Status	0x207D	Query modulator status
Query Mod Configuration	0x207E	Query modulator configuration
Query Mod Configuration & Status	0x207F	Query modulator configuration and status
Query Demod Diversity Status	0x2098	Query demodulator diversity status
Query Demod Channel Status	0x20B0	Query selected demodulator channel status
Query Demod Channel Configuration	0x20B1	Query selected demod channel configuration
Query Demod Channel Config & Status	0x20B2	Query selected demod channel config and status
Query Demod Status	0x20BD	Query demodulator status
Query Demod Configuration	0x20BE	Query demodulator configuration
Query Demod Configuration & Status	0x20BF	Query demodulator configuration and status
Query Tx Interface Status	0x2140	Query selected Tx interface status
Query Tx Interface Configuration	0x2141	Query selected Tx interface configuration
Query Tx Interface Config & Status	0x2142	Query selected Tx interface config and status
Query Tx Interface Jitter Control	0x2143	Query selected Tx interface jitter control
Query Rx Interface Status	0x2160	Query selected Rx interface status
Query Rx Interface Configuration	0x2161	Query selected Rx interface configuration
Query Rx Interface Config & Status	0x2162	Query selected Rx interface config and status
Query Rx Interface Jitter Control	0x2163	Query selected Rx interface jitter control
Query Rx Interface Byte Gapping	0x2164	Query selected Rx interface byte gap
Command Control Mode	0x2201	Set control mode
Command Time	0x2204	Set time
Command Date	0x2205	Set date
Command Time and Date	0x2206	Set time and date
Command Clear Latched Alarms	0x2207	Clear latched alarms
Command Common Alarm Mask	0x2208	Set common alarm mask
Command Last Rate Control	0x2209	Set last rate control
Command Frequency Plan	0x220A	Set IF frequency plan
Command User Mode	0x220B	Selects the user mode
Command Mux Loopback	0x220C	Selects the multiplexer loopback mode

Command Repeater Mode	0x220D	Selects the repeater mode
Command Mod Frequency	0x2240	Set modulator frequency
Command Mod Data Rate	0x2241	Set modulator data rate
Command Mod Symbol Rate	0x2242	Set modulator symbol rate
Command Mod Modulation	0x2244	Set modulator modulation
Command Mod Spectrum	0x2245	Set modulator spectrum
Command Mod Alarm Mask	0x224E	Set modulator alarm masks
Command Mod PRBS	0x224F	Set modulator PRBS
Command Mod Tx Power	0x2253	Set modulator power
Command Mod Carrier Control	0x2254	Set modulator control disable/enable
Command Mod Carrier Mode	0x2255	Set modulator carrier mode
Command Mod IF Separation	0x2258	Set modulator IF separation
Command Mod Channel Setting	0x2259	Set modulator channel setting
Command Mod User Frequencies	0x225A	Set modulator user frequencies
Command Mod Bandwidth	0x225B	Set modulator bandwidth
Command Mod Channel Config	0x2270	Set selected modulator channel configuration
Command Tx Interface Config	0x2271	Set selected Tx interface configuration
Command Tx Interface Jitter Control	0x2272	Set selected Tx interface jitter control
Command Demod Frequency	0x2280	Set demodulator frequency
Command Demod Data Rate	0x2281	Set demodulator data rate
Command Demod Symbol Rate	0x2282	Set demodulator symbol rate
Command Demod Demodulation	0x2284	Set demodulator demodulation
Command Demod Spectrum	0x2285	Set demodulator spectrum
Command Demod Alarm Mask	0x228E	Set demodulator alarm masks
Command Demod IF Separation	0x2298	Set demodulator IF separation
Command Demod Channel Setting	0x2299	Set demodulator channel setting
Command Demod User Frequencies	0x229A	Set demodulator user frequencies
Command Demod Bandwidth	0x229B	Set demodulator bandwidth
Command Demod Acquisition	0x229C	Set demodulator acquisition parameters
Command Demod Diversity Mode	0x229D	Command demodulator diversity mode
Command Demod Clear BER	0x229E	Clear demodulator BER
Command Demod Channel Config	0x22B0	Set selected demodulator channel configuration
Command Rx Interface Config	0x22B1	Set selected Rx interface configuration
Command Rx Interface Jitter Control	0x22B2	Set selected Rx interface jitter control
Command Rx Interface Byte Gapping	0x22B3	Set Selected Rx interface byte gap

A.3 Detailed Command Descriptions

Opcode: <0x2000> Query Identification

Query Response		
<1>	Modem Device ID	MM200 = 32 (0x20)

Opcode: <0x2001> Query current MM200 control mode

Query Response		
<1>	Mode	0 = Local 1 = Terminal 2 = Computer 3 = Ethernet

Opcode: <0x2002> Query software revision number

Query Response		
<1>	Revision Number	Binary value with implied decimal point, 35 means release 3.5

Opcode: <0x2003> Query firmware part number and release date

Query Response		
<8>	Part Number String	FW4459xx, xx represents the release version, example - B
<8>	Release Date String	ASCII representation of release date dd/mm/yy, 8 bytes in all

Opcode: <0x2004> Query time

Query Response		
<1>	Hour	0 – 23
<1>	Minute	0 – 59
<1>	Second	0 – 59

Opcode: <0x2005> Query date

Query Response		
<1>	Year	0 – 99
<1>	Month	0 – 11
<1>	Day	0 – 30

Opcode: <0x2006> Query time and date

Query Response		
<1>	Year	0 – 99
<1>	Month	0 – 11
<1>	Day	0 – 30
<1>	Hour	0 – 23
<1>	Minute	0 – 59

<1>	Second	0 – 59
-----	--------	--------

Opcode: <0x2010> Query current summary alarms

Query Response		
<1>	Modem Summary Fault	Bit 0 = MM200 global summary fault, set when the MM200 is faulted Bit 1 = Modulator summary fault, set when the modulator is faulting Bit 2 = Demodulator summary fault, set when the demodulator is faulting Bits 3 - 7 = Spares
<2>	Mod Summary Fault	Bit 0 = Modulator Fault Bit 1 = Modulator channel 1 fault Bit 2 = Modulator channel 2 fault Bit 3 = Modulator channel 3 fault Bit 4 = Modulator channel 4 fault Bit 5 = Modulator interface 1 fault Bit 6 = Modulator interface 2 fault Bit 7 = Modulator interface 3 fault Bit 8 = Modulator interface 4 fault Bits 9 – 15 = Spares
<2>	Demod Summary Fault	Bit 0 = Demodulator Fault Bit 1 = Demodulator channel 1 fault Bit 2 = Demodulator channel 2 fault Bit 3 = Demodulator channel 3 fault Bit 4 = Demodulator channel 4 fault Bit 5 = Demodulator interface 1 fault Bit 6 = Demodulator interface 2 fault Bit 7 = Demodulator interface 3 fault Bit 8 = Demodulator interface 4 fault Bits 9 – 15 = Spares

Opcode: <0x2011> Query latched summary alarms

Query Response		
<1>	Modem Summary Fault	Bit 0 = MM200 global summary fault, set when the MM200 is faulted Bit 1 = Modulator summary fault, set when the modulator is faulting Bit 2 = Demodulator summary fault, set when the demodulator is faulting Bits 3 - 7 = Spares
<2>	Mod Summary Fault	Bit 0 = Modulator Fault Bit 1 = Modulator channel 1 fault Bit 2 = Modulator channel 2 fault Bit 3 = Modulator channel 3 fault Bit 4 = Modulator channel 4 fault Bit 5 = Modulator interface 1 fault Bit 6 = Modulator interface 2 fault Bit 7 = Modulator interface 3 fault Bit 8 = Modulator interface 4 fault Bits 9 – 15 = Spares

<2>	Demod Summary Fault	Bit 0 = Demodulator Fault Bit 1 = Demodulator channel 1 fault Bit 2 = Demodulator channel 2 fault Bit 3 = Demodulator channel 3 fault Bit 4 = Demodulator channel 4 fault Bit 5 = Demodulator interface 1 fault Bit 6 = Demodulator interface 2 fault Bit 7 = Demodulator interface 3 fault Bit 8 = Demodulator interface 4 fault Bits 9 – 15 = Spares
-----	---------------------	---

Opcode: <0x203E> Query common configuration

Query Response		
<1>	Control Mode	0 = Local, 1 = Terminal, 2 = Remote, 3 = Ethernet
<1>	Last Rate Control	0 = Symbol, 1 = Data, 2 = Auto
<1>	User Mode	0 = Reserved, 1 = All Access, 2 = Level 1, 3 = Level 2
<1>	Frequency Plan	0 = Auto, 1 = User
<1>	Common Alarm 1 Mask	0 = Mask, 1 = Allow Bit 0 = Glue Logic CPLD Fail Bit 1 = M&C Test FPGA Fail Bits 2 – 7 = Spares
<1>	Common Alarm 2 Mask	0 = Mask, 1 = Allow Bits 0 – 7 = Spares
<1>	Mux Loopback	0 = Normal, 1 = Mux/Dmx Loop, 2 = Mux/Dmx LVDS, 3 = Modem LVDS, 4 = Repeater
<1>	Repeater Mode	0 = Off, 1 = On

Opcode: <0x2054> Query the carrier enable status

Query Response		
<1>	Carrier Status	0 = Off, 1 = On

Opcode: <0x2055> Query the carrier mode

Query Response		
<1>	Carrier Mode	0 = Normal 1 = CW 2 = Offset 1 Hz 3 = 100 kHz 4 = 3.5 MHz 5 = Sweep Up 6 = Sweep Down

Opcode: <0x2070> Query a selected modulator's channel status

Command Data Field 1 Byte		
<1>	Selected channel number	0 = channel1 1 = channel2 2 = channel3 3 = channel4

Query Response		
<1>	Selected channel number	0 = channel1 1 = channel2 2 = channel3 3 = channel4
<1>	Channel Major Alarm Status	0 = Pass, 1 = Fail Bit 0 = Mod daughter board FPGA status Bit 1 = RF PLL lock detect status Bit 2 - 7 = Spare
<1>	Channel Minor Alarm Status	0 = Pass, 1 = Fail Bit 0 = Loop lock status Bit 1 = FEC lock status Bit 2 = FIFO full status Bit 3 = FIFO empty status Bit 4 = FIFO active status Bit 5 - 7 = Spare
<1>	Channel Latched Major Alarm Status	0 = Pass, 1 = Fail Bit 0 = Mod daughter board FPGA status Bit 1 = RF PLL lock detect status Bit 2 - 7 = Spare
<1>	Channel Latched Minor Alarm Status	0 = Pass, 1 = Fail Bit 0 = Loop lock status Bit 1 = FEC lock status Bit 2 = FIFO full status Bit 3 = FIFO empty status Bit 4 = FIFO active status Bit 5 - 7 = Spare
<4>	Channel Baud Rate	7000000 – 200000000
<1>	Baud State	0 = Clock sourcing 1 = Out of lock 2 = Losing lock 3 = Acquiring 4 = Locked 5 = Too slow 6 = Too fast 7 = Searching up 8 = Searching down
<1>	Reserved	Spare

Opcode: <0x2071> Query a selected modulator's channel configuration

Command Data Field 1 Byte		
<1>	Selected channel number	0 = channel1 1 = channel2 2 = channel3 3 = channel4

Query Response		
<1>	Selected channel number	0 = channel1 1 = channel2 2 = channel3 3 = channel4
<1>	Channel Major Alarm Mask	0 = Mask, 1 = Allow Bit 0 = Mod daughter board FPGA status Bit 1 = RF PLL lock detect status Bit 2 - 7 = Spare
<1>	Channel Minor Alarm Mask	0 = Mask, 1 = Allow Bit 0 = Loop lock status Bit 1 = FEC lock status Bit 2 = FIFO full status Bit 3 = FIFO empty status Bit 4 = FIFO active status Bit 5 - 7 = Spare

Opcode: <0x2072> Query a selected modulator's channel configuration and status

Command Data Field 1 Byte		
<1>	Selected channel number	0 = channel1 1 = channel2 2 = channel3 3 = channel4
Query Response		
<1>	Selected channel number	0 = channel1 1 = channel2 2 = channel3 3 = channel4
<1>	Number of nonvol bytes*	Number of nonvol bytes for selected channel
	<p><i>* M&C developers MUST use this number of nonvolatile bytes to index into the selected channel status area. The nonvolatile data might grow with future firmware revisions. Refer to discussion on forward/backward compatibility.</i></p>	

<1>	Channel Major Alarm Mask	0 = Mask, 1 = Allow Bit 0 = Mod daughter board FPGA status Bit 1 = RF PLL lock detect status Bit 2 - 7 = Spare
<1>	Channel Minor Alarm Mask	0 = Mask, 1 = Allow Bit 0 = Loop lock status Bit 1 = FEC lock status Bit 2 = FIFO full status Bit 3 = FIFO empty status Bit 4 = FIFO active status Bit 5 - 7 = Spare
Status Bytes		
<1>	Channel Major Alarm Status	0 = Pass, 1 = Fail Bit 0 = Mod daughter board FPGA status Bit 1 = RF PLL lock detect status Bit 2 - 7 = Spare
<1>	Channel Minor Alarm Status	0 = Pass, 1 = Fail Bit 0 = Loop lock status Bit 1 = FEC lock status Bit 2 = FIFO full status Bit 3 = FIFO empty status Bit 4 = FIFO active status Bit 5 - 7 = Spare
<1>	Channel Latched Major Alarm Status	0 = Pass, 1 = Fail Bit 0 = Mod daughter board FPGA status Bit 1 = RF PLL lock detect status Bit 2 - 7 = Spare
<1>	Channel Latched Minor Alarm Status	0 = Pass, 1 = Fail Bit 0 = Loop lock status Bit 1 = FEC lock status Bit 2 = FIFO full status Bit 3 = FIFO empty status Bit 4 = FIFO active status Bit 5 - 7 = Spare
<4>	Channel Baud Rate	7000000 – 200000000
<1>	Baud State	0 = Clock sourcing 1 = Out of lock 2 = Losing lock 3 = Acquiring 4 = Locked 5 = Too slow 6 = Too fast 7 = Searching up 8 = Searching down
<1>	Reserved	Spare

Opcode: <0x207D> Query a modulator's status

Query Response		
<1>	Major Alarm1 Status	0 = Pass, 1 = Fail Bit 0 = Glue Logic FPGA Fail Bit 1 = Data FPGA Fail Bits 2 – 7 = Spare
<1>	Major Alarm2 Status	0 = Pass, 1 = Fail Bits 0 - 7= Spare
<1>	Minor Alarm1 Status	0 = Pass, 1 = Fail Bit 0 = Tx clock activity detect Bit 1 = Tx data activity detect Bit 2 = Frame Lock Bits 3 – 7 = Spare
<1>	Minor Alarm2 Status	0 = Pass, 1 = Fail Bits 0 – 7 = Spare
<1>	Common Alarm1 Status	0 = Pass, 1 = Fail Bit 0 = Glue Logic FPGA Fail Bit 1 = Test FPGA Fail Bits 2 – 7 = Spare
<1>	Common Alarm2 Status	0 = Pass, 1 = Fail Bits 0 – 7 = Spare
<1>	Latched Major Alarm1 Status	0 = Pass, 1 = Fail Bit 0 = Glue Logic FPGA Fail Bit 1 = Data FPGA Fail Bits 2 – 7 = Spare
<1>	Latched Major Alarm2 Status	0 = Pass, 1 = Fail Bits 0 – 7 = Spare
<1>	Latched Minor Alarm1 Status	0 = Pass, 1 = Fail Bit 0 = Tx clock activity detect Bit 1 = Tx data activity detect Bit 2 = Frame Lock Bits 3 – 7 = Spare
<1>	Latched Minor Alarm2 Status	0 = Pass, 1 = Fail Bits 0 – 7 = Spare
<1>	Latched Common Alarm1 Status	0 = Pass, 1 = FailBit Bit 0 = Glue Logic FPGA Fail Bit 1 = Test FPGA Fail Bits 2 – 7 = Spare
<1>	Latched Common Alarm2 Status	0 = Pass, 1 = Fail Bits 0 – 7 = Spare
<1>	Carrier Status	0 = off, 1 = on
<1>	Spare	
<4>	Max Payload	Maximum payload at current modulation

<2>	Utilization	% utilization, implied decimal point (i.e. 7985 means 79.85%)
<4>	Bandwidth	Current bandwidth usage
<4>	APC Minimum Tx Level	Minimum APC transmit level (Not Yet Implemented)

Opcode: <0x207E> Query a modulator's configuration

Query Response		
<4>	Data Rate	7000000 - 200000000
<4>	Symbol Rate	3500000 - 28000000
<4>	IF Frequency	50000000 - 90000000
<4>	Transmit Power	-250 to 0, implied decimal point
<1>	Carrier Control	0 = off, 1 = on
<1>	IF Separation	100 - 150%
<1>	Modulation	0 = qam4 1 = qam16 2 = qam32 3 = qam64 4 = qam128 5 = qam256
<1>	Spectrum	0 = normal, 1 = inverted
<1>	Carrier Mode	0 = Normal 1 = CW 2 = Offset 1Hz 3 = 100KHz 4 = 3.5MHz 5 = Sweep Up 6 = Sweep Down
<1>	Channel Setting	0 = auto 1 = one 2 = two 3 = three 4 = four 5 = debug
<1>	Major Alarm1 Mask	0 = Mask, 1 = Allow Bit 0 = Glue Logic FPGA Fail Bit 1 = Data FPGA Fail Bits 2 – 7 = Spare
<1>	Major Alarm2 Mask	0 = Mask, 1 = Allow Bit 0 – 7 = Spare
<1>	Minor Alarm1 Mask	0 = Mask, 1 = Allow Bit 0 = Tx clock activity detect Bit 1 = Tx data activity detect Bit 2 = Frame Lock

		Bit 3 – 7 = Spare
<1>	Minor Alarm2 Mask	0 = Mask, 1 = Allow Bit 0 – 7 = Spare
<1>	Common Alarm1 Mask	0 = Mask, 1 = Allow Bit 0 = Glue Logic FPGA Fail Bit 1 = Test FPGA Fail Bits 2 – 7 = Spare
<1>	Common Alarm2 Mask	0 = Mask, 1 = Allow Bit 0 – 7 = Spare
<1>	Control Mode	0 = local 1 = terminal 2 = computer 3 = Ethernet
<1>	PRBS	0 = normal 1 = prbs_23 2 = prbs_23m 3 = prbs_15 4 = prbs_15m
<1>	Last Rate Control	0 = symbol 1 = data 2 = auto
<1>	User Mode	0 = Debug 1 = All access 2 = Level 1 3 = Level 2
<1>	APC Control	Sets APC transmit control (Not Yet Implemented)
<4>	APC Maximum Tx Level	Maximum APC transmit level (Not Yet Implemented)
<4>	APC Default Tx Level	Default APC transmit level (Not Yet Implemented)
<4>	APC Speed	Sets the speed at which the transmitter changes (Not Yet Implemented)
<1>	APC Step Size	Sets the amount each APC command changes the transmitter (Not Yet Implemented)
<1>	APC Range	Controls the APC transmit power range (Not Yet Implemented)

Opcode: <0x207F> Query a modulator's configuration and status

Query Response	
<1>	Number of nonvol bytes* * M&C developers <i>MUST</i> use this number of nonvolatile

	<i>bytes to index into the selected channel status area. The nonvolatile data might grow with future firmware revisions. Refer to discussion on forward/backward compatibility.</i>	
<4>	Data Rate	7000000 - 200000000
<4>	Symbol Rate	3500000 - 28000000
<4>	IF Frequency	50000000 - 90000000
<4>	Transmit Power	-200 to 0
<1>	Carrier Control	0 = off, 1 = on
<1>	IF Separation	100 - 150%
<1>	Modulation	0 = qam4 1 = qam16 2 = qam32 3 = qam64 4 = qam128 5 = qam256
<1>	Spectrum	0 = normal, 1 = inverted
<1>	Carrier Mode	0 = Normal 1 = CW 2 = Offset 1Hz 3 = 100KHz 4 = 3.5MHz 5 = Sweep Up 6 = Sweep Down
<1>	Channel Setting	0 = auto 1 = one 2 = two 3 = three 4 = four 5 = debug
<1>	Major Alarm 1 Mask	0 = Mask, 1 = Allow Bit 0 = Glue Logic FPGA Fail Bit 1 = Data FPGA Fail Bit 2 – 7 = Spare
<1>	Major Alarm2 Mask	0 = Mask, 1 = Allow Bit 0 – 7 = Spare
<1>	Minor Alarm1 Mask	0 = Mask, 1 = Allow Bit 0 = Tx clock activity detect Bit 1 = Tx data activity detect Bit 2 = Frame Lock

		Bit 3 – 7 = Spare
<1>	Minor Alarm2 Mask	0 = Mask, 1 = Allow Bit 0 – 7 = Spare
<1>	Common Alarm1 Mask	0 = Mask, 1 = Allow Bit 0 = Glue Logic CPLD Fail Bit 1 = Test FPGA Fail Bits 2 – 7 = Spare
<1>	Common Alarm2 Mask	0 = Mask, 1 = Allow Bit 0 – 7 = Spare
<1>	Control Mode	0 = local 1 = terminal 2 = computer 3 = Ethernet
<1>	PRBS	0 = normal 1 = prbs_23 2 = prbs_23m 3 = prbs_15 4 = prbs_15m
<1>	Last Rate Control	0 = symbol 1 = data 2 = auto
<1>	User Mode	0 = Debug 1 = All Access 2 = Level 1 3 = Level 2
<1>	APC Control	Sets APC transmit control (Not Yet Implemented)
<4>	APC Maximum Tx Level	Maximum APC transmit level (Not Yet Implemented)
<4>	APC Default Tx Level	Default APC transmit level (Not Yet Implemented)
<4>	APC Speed	Sets the speed at which the transmitter changes (Not Yet Implemented)
<1>	APC Step Size	Sets the amount each APC command changes the transmitter (Not Yet Implemented)
<1>	APC Range	Controls the APC transmit power range (Not Yet Implemented)
Status Bytes		
<1>	Major Alarm1 Status	0 = Pass, 1 = Fail Bit 0 = Glue Logic FPGA Fail Bit 1 = Data FPGA Fail Bits 2 – 7 = Spare
<1>	Major Alarm2 Status	0 = Pass, 1 = Fail Bits 0 – 7 = Spare

<1>	Minor Alarm1 Status	0 = Pass, 1 = Fail Bit 0 = Tx clock activity detect Bit 1 = Tx data activity detect Bit 2 = Frame Lock Bits 3 – 7 = Spare
<1>	Minor Alarm2 Status	0 = Pass, 1 = Fail Bits 0 – 7 = Spare
<1>	Common Alarm1 Status	0 = Mask, 1 = Allow Bit 0 = Glue Logic FPGA Fail Bit 1 = Data FPGA Fail Bits 2 – 7 = Spare
<1>	Common Alarm2 Status	0 = Pass, 1 = Fail Bits 0 – 7 = Spare
<1>	Latched Major Alarm1 Status	0 = Pass, 1 = Fail Bit 0 = Glue Logic FPGA Fail Bit 1 = Data FPGA Fail Bits 2 – 7 = Spare
<1>	Latched Major Alarm2 Status	0 = Pass, 1 = Fail Bits 0 – 7 = Spare
<1>	Latched Minor Alarm1 Status	0 = Pass, 1 = Fail Bit 0 = Tx clock activity detect Bit 1 = Tx data activity detect Bit 2 = Frame Lock Bit 3 = Spare Bits 4 – 7 = Spare
<1>	Latched Minor Alarm2 Status	0 = Pass, 1 = Fail Bits 0 – 7 = Spare
<1>	Latched Common Alarm1 Status	0 = Pass, 1 = Fail Bits 0 – 7 = Spare
<1>	Latched Common Alarm2 Status	0 = Pass, 1 = Fail Bits 0 – 7 = Spare
<1>	Carrier Status	0 = off, 1 = on
<1>	Spare	
<4>	Max Payload	Maximum payload at current modulation
<2>	Utilization	% utilization, implied decimal point (i.e. 7985 means 79.85%)
<4>	Bandwidth	Current bandwidth usage
<4>	APC Minimum Tx Level	Minimum APC transmit level (Not Yet Implemented)

Opcode: <0x2098> Query the demodulator diversity status

Query Response		
<1>	Diversity Mux Status	0 = Unused, 1 = Channel A, 2 = Channel B, 3 = Null framer
<1>	Diversity FIFO A Status	0 = No flags, 1 = Empty, 2 = Full
<1>	Diversity FIFO B Status	0 = No flags, 1 = Empty, 2 = Full
<1>	Reserved	Spare
<2>	Channel A Error Counter	0 – xxx, where xxx is the current error count
<2>	Channel B Error Counter	0 – xxx, where xxx is the current error count
<2>	Channel AB Error Counter	0 – xxx, where xxx is the current error count

Opcode: <0x20B0> Query a selected demodulator's channel status

Command Data Field 1 Byte		
<1>	Selected channel number	0 = channel1 1 = channel2 2 = channel3 3 = channel4
Query Response		
<1>	Selected channel	0 = channel1 1 = channel2 2 = channel3 3 = channel4
<1>	Channel Major Alarm Status	0 = Pass, 1 = Fail Bit 0 = Demod daughter board FPGA status Bit 1 = RF PLL lock detect status Bits 2 - 7 = Spare
<1>	Channel Minor Alarm Status	0 = Pass, 1 = Fail Bit 0 = QAM lock status Bit 1 = FEC lock status Bit 2 = FIFO full status Bit 3 = FIFO empty status Bit 4 = Sync lock status Bit 5 = FIFO reload status Bit 6 = FIFO pos status Bit 7 = Track fault status
<1>	Channel Latched Major Alarm Status	0 = Pass, 1 = Fail Bit 0 = Demod daughter board FPGA status Bit 1 = RF PLL lock detect status Bit 2 - 7 = Spare
<1>	Channel Latched Minor Alarm Status	0 = Pass, 1 = Fail Bit 0 = QAM lock status Bit 1 = FEC lock status Bit 2 = FIFO full status

		Bit 3 = FIFO empty status Bit 4 = Sync lock status Bit 5 = FIFO reload status Bit 6 = FIFO pos status Bit 7 = Track fault status
<4>	Channel Baud Rate	7000000 - 200000000
<4>	Channel Offset Frequency	Binary value in Hz
<4>	Channel AGC Integrator	AGC integrator
<4>	Channel SNR	Signal-to-noise ratio, 00.00 - 99.00 dB, implied decimal point
<4>	Channel CBA	Correctable blocks accumulator
<4>	Channel UBA	Uncorrectable blocks accumulator
<2>	Input Level	Channel input level in dBm. Signed implied decimal point (-265 means -26.5 dBm)
<4>	Pre FEC BER	Floating point format following IEEE Standard 754*
<4>	Post FEC BER	Floating point format following IEEE Standard 754*
		* Refer to Appendix C for IEEE Standard 754 – Floating Point Numbers

Opcode: <0x20B1> Query a selected demodulator's channel configuration

Command Data Field 1 Byte		
<1>	Selected channel number	0 = channel1 1 = channel2 2 = channel3 3 = channel4
Query Response		
<1>	Selected channel Number	0 = channel1 1 = channel2 2 = channel3 3 = channel4
<1>	Channel Major Alarm Mask	0 = Mask, 1 = Allow Bit 0 = Demod daughter board FPGA status Bit 1 = RF PLL lock detect status Bits 2 - 7 = Spare
<1>	Channel Minor Alarm Mask	0 = Mask, 1 = Allow Bit 0 = QAM lock status Bit 1 = FEC lock status Bit 2 = FIFO full status Bit 3 = FIFO empty status Bit 4 = Sync lock status Bit 5 = FIFO reload status Bit 6 = FIFO pos status

	Bit 7 = Track fault status
--	----------------------------

Opcode: <0x20B2> Query a selected demodulator's channel configuration and status

Command Data Field 1 Byte		
<1>	Selected channel number	0 = channel1 1 = channel2 2 = channel3 3 = channel4
Query Response		
<1>	Selected channel Number	0 = channel1 1 = channel2 2 = channel3 3 = channel4
<1>	Number of nonvol bytes* <i>* M&C developers MUST use this number of nonvolatile bytes to index into the selected channel status area. The nonvolatile data might grow with future firmware revisions. Refer to discussion on forward/backward compatibility.</i>	Number of nonvol bytes for selected channel
<1>	Channel Major Alarm Mask	0 = Mask, 1 = Allow Bit 0 = Demod daughter board FPGA status Bit 1 = RF PLL lock detect status Bit 2 - 7 = Spare
<1>	Channel Minor Alarm Mask	0 = Mask, 1 = Allow Bit 0 = QAM lock status Bit 1 = FEC lock status Bit 2 = FIFO full status Bit 3 = FIFO empty status Bit 4 = Sync lock status Bit 5 = FIFO reload status Bit 6 = FIFO pos status Bit 7 = Track fault status
Status Bytes		
<1>	Channel Major Alarm Status	0 = Pass, 1 = Fail Bit 0 = Demod daughter board FPGA status Bit 1 = RF PLL lock detect status Bits 2 - 7 = Spare
<1>	Channel Minor Alarm Status	0 = Pass, 1 = Fail Bit 0 = QAM lock status Bit 1 = FEC lock status Bit 2 = FIFO full status

		Bit 3 = FIFO empty status Bit 4 = Sync lock status Bit 5 = FIFO reload status Bit 6 = FIFO pos status Bit 7 = Track fault status
<1>	Channel Latched Major Alarm Status	0 = Pass, 1 = Fail Bit 0 = Demod daughter board FPGA status Bit 1 = RF PLL lock detect status Bits 2 - 7 = Spare
<1>	Channel Latched Minor Alarm Status	0 = Pass, 1 = Fail Bit 0 = QAM lock status Bit 1 = FEC lock status Bit 2 = FIFO full status Bit 3 = FIFO empty status Bit 4 = Sync lock status Bit 5 = FIFO reload status Bit 6 = FIFO pos status Bit 7 = Track fault status
<4>	Channel Baud Rate	7000000 - 200000000
<4>	Channel Offset Frequency	Binary value in Hz
<4>	Channel AGC Integrator	AGC integrator
<4>	Channel SNR	Signal-to-noise ratio, 00.00 - 99.00 dB, implied decimal point
<4>	Channel CBA	Correctable blocks accumulator
<4>	Channel UBA	Uncorrectable blocks accumulator
<2>	Input Level	Channel input level in dBm. Signed implied decimal point (-265 means -26.5 dBm)
<4>	Pre FEC BER	Floating point format following IEEE Standard 754*
<4>	Post FEC BER	Floating point format following IEEE Standard 754*
		* Refer to Appendix C for IEEE Standard 754 – Floating Point Numbers

Opcode: <0x20BD> Query a demodulator's status

Query Response		
<1>	Major Alarm1	0 = Pass, 1 = Fail Bit 0 = Glue Logic FPGA Fail Bit 1 = Data FPGA Fail Bit 2 = Signal Lock Detect Bit 3 = Sync Lock Detect Bit 4 = Deframer clock PLL lock detect Bit 5 = Diversity FPGA fail Bits 6 – 7 = Spare
<1>	Major Alarm2	0 = Pass, 1 = Fail

	Status	Bits 0 – 7 = Spare
<1>	Minor Alarm1 Status	0 = Pass, 1 = Fail Bits 0 – 7 = Spare
<1>	Minor Alarm2 Status	0 = Pass, 1 = Fail Bits 0 – 7 = Spare
<1>	Common Alarm1 Status	0 = M&C Mask, 1 = Allow Bit 0 = Glue Logic CPLD Fail Bit 1 = M&C Test FPGA Fail Bits 2 – 7 = Spare
<1>	Common Alarm2 Status	0 = Pass, 1 = Fail Bits 0 – 7 = Spare
<1>	Latched Major Alarm1 Status	0 = Pass, 1 = Fail Bit 0 = Glue Logic FPGA Fail Bit 1 = Data FPGA Fail Bit 2 = Signal Lock Detect Bit 3 = Sync Lock Detect Bit 4 = Deframer clock PLL lock detect Bit 5 = Diversity FPGA fail Bit 6 – 7 = Spare
<1>	Latched Major Alarm2 Status	0 = Pass, 1 = Fail Bits 0 – 7 = Spare
<1>	Latched Minor Alarm1 Status	0 = Pass, 1 = Fail Bits 0 – 7 = Spare
<1>	Latched Minor Alarm2 Status	0 = Pass, 1 = Fail Bits 0 – 7 = Spare
<1>	Latched Common Alarm1 Status	0 = M&C Mask, 1 = Allow Bit 0 = Glue Logic CPLD Fail Bit 1 = M&C Test FPGA Fail Bits 2 – 7 = Spare
<1>	Latched Common Alarm2 Status	0 = Pass, 1 = Fail Bits 0 – 7 = Spare
<4>	Max Payload	Maximum payload at current demodulation
<2>	Utilization	% utilization. Implied decimal point (i.e. 7985 means 79.85%)
<4>	Bandwidth	Current bandwidth usage
<2>	Input Level	Aggregate input level in dBm. Signed implied decimal point (i.e. -265 means -26.5 dBm)

Opcode: <0x20BE> Query a demodulator's configuration

Query Response		
<4>	Data Rate	7000000 - 200000000
<4>	Symbol Rate	3500000 - 28000000

<4>	IF Frequency	50000000 - 90000000
<1>	IF Separation	100 - 150%
<1>	Demodulation	0 = qam4 1 = qam16 2 = qam32 3 = qam64 4 = qam128 5 = qam256
<1>	Spectrum	0 = normal, 1 = inverted
<1>	Channel Setting	0 = auto 1 = one 2 = two 3 = three 4 = four 5 = debug
<1>	Major Alarm1 Mask	0 = Mask, 1 = Allow Bit 0 = Glue Logic FPGA Fail Bit 1 = Data FPGA Fail Bit 2 = Signal Lock Detect Bit 3 = Sync Lock Detect Bit 4 = Deframer clock PLL lock detect Bit 5 = Diversity FPGA fail Bits 6 – 7 = Spare
<1>	Major Alarm2 Mask	0 = Mask, 1 = Allow Bits 0 – 7 = Spare
<1>	Minor Alarm1 Mask	0 = Mask, 1 = Allow Bits 0 – 7 = Spare
<1>	Minor Alarm2 Mask	0 = Mask, 1 = Allow Bits 0 – 7 = Spare
<1>	Common Alarm1 Mask	0 = Mask, 1 = Allow Bit 0 = Glue Logic FPGA Fail Bit 1 = Data FPGA Fail Bit 2 – 7 = Spare
<1>	Common Alarm2 Mask	0 = Mask, 1 = Allow Bits 0 – 7 = Spare
<1>	Control Mode	0 = local 1 = terminal 2 = computer 3 = Ethernet
<1>	Last Rate Control	0 = symbol 1 = data 2 = auto
<1>	User Mode	0 = Debug 1 = All Access 2 = Level 1

		3 = Level 2
<1>	Acquisition Control	0 = Off, 1 = Acquire
<2>	Acquisition Bandwidth	50 – 400 kHz, 1 kHz steps
<1>	Acquisition Delay	10 – 255 sec, 1 sec steps
<1>	Acquisition Step	10 – 100 kHz, 1 kHz steps
<1>	Tracking Step	10 – 100 Hz, 1 Hz steps
<1>	Re-acquisition Delay	10 – 255 sec, 1 sec steps
<1>	APC Control	Sets the APC receive control (Not Yet Implemented)
<1>	APC Hysteresis	Sets the APC receive hysteresis level (Not Yet Implemented)
<4>	APC Level	Sets the APC receive level in dBm (Not Yet Implemented)

Opcode: <0x20BF> Query a demodulator's configuration and status

Query Response		
<1>	Number of nonvol bytes* <i>* M&C developers MUST use this number of nonvolatile bytes to index into the selected channel status area. The nonvolatile data might grow with future firmware revisions. Refer to discussion on forward/backward compatibility.</i>	<1> Number of nonvol bytes*
<4>	Data Rate	7000000 - 200000000
<4>	Symbol Rate	3500000 - 28000000
<4>	IF Frequency	50000000 - 90000000
<1>	IF Separation	120 - 150
<1>	Demodulation	0 = qam4 1 = qam16 2 = qam32 3 = qam64 4 = qam128 5 = qam256
<1>	Spectrum	0 = normal, 1 = inverted

<1>	Channel Setting	0 = auto 1 = one 2 = two 3 = three 4 = four
<1>	Major Alarm1 Mask	0 = Mask, 1 = Allow Bit 0 = Glue Logic FPGA Fail Bit 1 = Data FPGA Fail Bit 2 = Signal Lock Detect Bit 3 = Sync Lock Detect Bit 4 = Deframer clock PLL lock detect Bit 5 = Diversity FPGA fail Bits 6 – 7 = Spare
<1>	Major Alarm2 Mask	0 = Mask, 1 = Allow Bits 0 – 7 = Spare
<1>	Minor Alarm1 Mask	0 = Mask, 1 = Allow Bits 0 – 7 = Spare
<1>	Minor Alarm2 Mask	0 = Mask, 1 = Allow Bits 0 – 7 = Spare
<1>	Common Alarm1 Mask	0 = Mask, 1 = Allow Bit 0 = Glue Logic FPGA Fail Bit 1 = Data FPGA Fail Bits 2 – 7 = Spare
<1>	Common Alarm2 Mask	0 = Mask, 1 = Allow Bits 0 – 7 = Spare
<1>	Control Mode	0 = local 1 = terminal 2 = computer 3 = Ethernet
<1>	Last Rate Control	0 = symbol 1 = data 2 = auto
<1>	User Mode	0 = Debug 1 = All Access 2 = Level 1 3 = Level 2
<1>	Acquisition Control	0 = Off, 1 = Acquire
<2>	Acquisition Bandwidth	50 – 400 kHz, 1 kHz steps
<1>	Acquisition Delay	10 – 255 sec, 1 sec steps
<1>	Acquisition Step	10 – 100 kHz, 1 kHz steps
<1>	Tracking Step	10 – 100 Hz, 1 Hz steps
<1>	Re-acquisition Delay	10 – 255 sec, 1 sec steps

<1>	APC Control	Sets the APC receive control (Not Yet Implemented)
<1>	APC Hysteresis	Sets the APC receive hysteresis level (Not Yet Implemented)
<4>	APC Level	Sets the APC receive level in dBm (Not Yet Implemented)
Status Bytes		
<1>	Major Alarm1 Status	0 = Pass, 1 = Fail Bit 0 = Glue Logic FPGA Fail Bit 1 = Data FPGA Fail Bit 2 = Signal Lock Detect Bit 3 = Sync Lock Detect Bit 4 = Deframer clock PLL lock detect Bit 5 = Diversity FPGA fail Bits 6 – 7 = Spare
<1>	Major Alarm2 Status	0 = Pass, 1 = Fail Bits 0 – 7 = Spare
<1>	Minor Alarm1 Status	0 = Pass, 1 = Fail Bits 0 – 7 = Spare
<1>	Minor Alarm2 Status	0 = Pass, 1 = Fail Bits 0 – 7 = Spare
<1>	Common Alarm1 Status	0 = Pass, 1 = Fail Bit 0 = Glue Logic FPGA Fail Bit 1 = Data FPGA Fail Bits 2 – 7 = Spare
<1>	Common Alarm2 Status	0 = Pass, 1 = Fail Bits 0 – 7 = Spare
<1>	Latched Major Alarm1 Status	0 = Pass, 1 = Fail Bit 0 = Glue Logic FPGA Fail Bit 1 = Data FPGA Fail Bit 2 = Signal Lock Detect Bit 3 = Sync Lock Detect Bit 4 = Deframer clock PLL lock detect Bit 5 = Diversity FPGA fail Bits 6 – 7 = Spare
<1>	Latched Major Alarm2 Status	0 = Pass, 1 = Fail Bits 0 – 7 = Spare
<1>	Latched Minor Alarm1 Status	0 = Pass, 1 = Fail Bits 0 – 7 = Spare
<1>	Latched Minor Alarm2 Status	0 = Pass, 1 = Fail Bits 0 – 7 = Spare
<1>	Latched Common Alarm1 Status	0 = Pass, 1 = Fail Bit 0 = Glue Logic FPGA Fail Bit 1 = Data FPGA Fail Bits 2 – 7 = Spare
<1>	Latched Common Alarm2	0 = Pass, 1 = Fail Bits 0 – 7 = Spare

Status		
<4>	Max Payload	Maximum payload at current demodulation
<2>	Utilization	% utilization. Implied decimal point (i.e. 7985 means 79.85%)
<4>	Bandwidth	Current bandwidth usage
<2>	Input Level	Aggregate input level in dBm. Signed implied decimal point (i.e. -265 means -26.5 dBm)

Opcode: <0x2140> Query selected Tx interface status

Command Data Field 1 Byte		
<1>	Selected interface number	0 = interface1 1 = interface2 2 = interface3 3 = interface4
Query Response		
<1>	Selected interface number	0 = interface1 1 = interface2 2 = interface3 3 = interface4
<1>	Interface Major Alarm1 Status	0 = Pass, 1 = Fail Bit 0 = Interface Test Bit 1 - 7 = Spare
<1>	Interface Minor Alarm1 Status	0 = Pass, 1 = Fail Bit 0 = Interface FIFO full Bit 1 = Interface FIFO empty Bit 2 = PLL lock Bit 3 = Interface data activity detect Bit 4 = Interface clock activity detect Bit 5 = Interface Tx input framing valid, added for AASI Bit 6 = Interface signal loss, valid for some interfaces Bit 7 = Spare
<1>	Interface Latched Major Alarm1	Status 0 = Pass, 1 = Fail Bit 0 = Interface Test Bit 1 - 7 = Spare
<1>	Interface Latched Minor Alarm1 Status	0 = Pass, 1 = Fail Bit 0 = Interface FIFO full Bit 1 = Interface FIFO empty Bit 2 = PLL lock Bit 3 = Interface data activity detect Bit 4 = Interface clock activity detect Bit 5 = Interface Tx input framing valid, added for AASI Bit 6 = Interface signal loss, valid for some interfaces Bit 7 = Spare
<1>	Interface Card	0 = None 1 = ASI/AASI 2 = ASIS 3 = NASI 4 = T3E3

<1>	Reserved	5 = T1E1 6 = DSO 7 = PAR 8 = OC3 9 = HSSI 10 = SMPTE 11 = P10BaseT 12 = T2E2 Spare
-----	----------	--

Opcode: <0x2141> Query selected Tx interface configuration

Command Data Field 1 Byte		
<1>	Selected interface number	0 = interface1 1 = interface2 2 = interface3 3 = interface4
Query Response		
<1>	Selected interface number	0 = interface1 1 = interface2 2 = interface3 3 = interface4
<4>	Interface PID	0 - 8192
<4>	Interface Data Rate	1000000 - 200000000
<1>	Interface Control	0 = Disable, 1 = Enable
<1>	Interface Type	0 = ASI 1 = AASI 2 = T3 DS3 3 = E3 4 = STS1 5 = T1 DS1 6 = E1 7 = DS0x8 8 = DS0x7+A 9 = Par DVB 10 = Par M2P 11 = OC3 12 = STM1 13 = HSSI 14 = SMPTE19 15 = SMPTE 38 16 = P 10BaseT 17 = E2 UNBAL 18 = T2 UNBAL 19 = T2 BAL 20 = DS0 APC
<1>	Interface Sub Type	Reserved, selects the Tx interface sub-type
<1>	Interface Framing	0 = unframed

		1 = MPEG 188 2 = MPEG 204
<1>	Interface Volume	0 = 255
<1>	Interface Clock Polarity	0 = normal 1 = inverted 2 = auto
<1>	Interface Data Polarity	0 = normal, 1 = inverted
<1>	Interface Baseband Loopback	0 = disable, 1 = enable
<1>	Reserved	Spare
<1>	Interface PRBS	0 = normal 1 = prbs_23 2 = prbs_23m 3 = prbs_15 4 = prbs_15m (Not Yet Implemented)
<1>	Interface Major Alarm1 Mask	0 = Mask, 1 = Allow Bit 0 = Interface Test Bit 1 - 7 = Spare
<1>	Interface Minor Alarm1 Mask	0 = Mask, 1 = Allow Bit 0 = Interface FIFO full Bit 1 = Interface FIFO empty Bit 2 = PLL lock Bit 3 = Interface data activity detect Bit 4 = Interface clock activity detect Bit 5 = Interface Tx input framing valid, added for AASI Bit 6 = Interface signal loss, valid for some interfaces Bit 7 = Spare

Opcode: <0x2142> Query selected Tx interface configuration and status

Command Data Field 1 Byte		
<1>	Selected interface number	0 = interface1 1 = interface2 2 = interface3 3 = interface4
Query Response		
<1>	Selected interface number	0 = interface1 1 = interface2 2 = interface3 3 = interface4
<1>	Number of nonvol bytes* * M&C developers MUST use this number of nonvolatile	Number of nonvol bytes for selected interface

	<i>bytes to index into the selected interface status area. The nonvolatile data might grow with future firmware revisions. Refer to discussion on forward/backward compatibility.</i>	
<4>	Interface PID	0 - 8192
<4>	Interface Data Rate	1000000 - 200000000
<1>	Interface Control	0 = Disable, 1 = Enable
<1>	Interface Type	0 = ASI 1 = AASI 2 = T3 DS3 3 = E3 4 = STS1 5 = T1 DS1 6 = E1 7 = DS0x8 8 = DS0x7+A 9 = Par DVB 10 = Par M2P 11 = OC3 12 = STM1 13 = HSSI 14 = SMPTE 19 15 = SMPTE 38 16 = P 10BaseT 17 = E2 UNBAL 18 = T2 UNBAL 19 = T2 BAL 20 = DS0 APC
<1>	Interface Sub Type	Reserved, selects the Tx interface sub-type
<1>	Interface Framing	0 = unframed 1 = MPEG 188 2 = MPEG 204
<1>	Interface Volume	0 - 255
<1>	Interface Clock Polarity	0 = normal, 1 = inverted
<1>	Interface Data Polarity	0 = normal, 1 = inverted
<1>	Interface Baseband Loopback	0 = disable, 1 = enable

<1>	Reserved	Spare
<1>	Interface PRBS	0 = normal 1 = prbs_23 2 = prbs_23m 3 = prbs_15 4 = prbs_15m (Not Yet Implemented)
<1>	Interface Major Alarm1 Mask	0 = Mask, 1 = Allow Bit 0 = Interface Test Bit 1 - 7 = Spare
<1>	Interface Minor Alarm1 Mask	0 = Mask, 1 = Allow Bit 0 = Interface FIFO full Bit 1 = Interface FIFO empty Bit 2 = PLL lock Bit 3 = Interface data activity detect Bit 4 = Interface clock activity detect Bit 5 = Interface Tx input framing valid, added for AASI Bit 6 = Interface signal loss, valid for some interfaces Bit 7 = Spare
Status Bytes		
<1>	Interface Major Alarm1	Status 0 = Pass, 1 = Fail Bit 0 = Interface Test Bit 1 - 7 = Spare
<1>	Interface Minor Alarm1	Status 0 = Pass, 1 = Fail Bit 0 = Interface FIFO full Bit 1 = Interface FIFO empty Bit 2 = PLL lock Bit 3 = Interface data activity detect Bit 4 = Interface clock activity detect Bit 5 = Interface Tx input framing valid, added for AASI Bit 6 = Interface signal loss, valid for some interfaces Bit 7 = Spare
<1>	Interface Latched Major Alarm1	Status 0 = Pass, 1 = Fail Bit 0 = Interface Test Bit 1 - 7 = Spare
<1>	Interface Latched Minor Alarm1 Status	0 = Pass, 1 = Fail Bit 0 = Interface FIFO full Bit 1 = Interface FIFO empty Bit 2 = PLL lock Bit 3 = Interface data activity detect Bit 4 = Interface clock activity detect Bit 5 = Interface Tx input framing valid, added for AASI Bit 6 = Interface signal loss, valid for some interfaces Bit 7 = Spare
<1>	Interface Card	0 = None 1 = ASI/AASI 2 = ASIS 3 = NASI

<1>	Reserved	4 = T3E3 5 = T1E1 6 = DSO 7 = PAR 8 = OC3 9 = HSSI 10 = SMPTE 11 = P10BaseT 12 = T2E2 Spare
-----	----------	--

Opcode: <0x2143> Query selected Tx interface jitter control

Command Data Field 1 Byte		
<1>	Selected interface number	0 = interface1 1 = interface2 2 = interface3 3 = interface4
Query Response		
<1>	Selected interface number	0 = interface1 1 = interface2 2 = interface3 3 = interface4
<1>	Jitter Control	0 = Normal, 1 = Stamp2, 2 = Stamp3

Opcode: <0x2160> Query selected Rx interface status

Command Data Field 1 Byte		
<1>	Selected interface number	0 = interface1 1 = interface2 2 = interface3 3 = interface4
Query Response		
<1>	Selected interface number	0 = interface1 1 = interface2 2 = interface3 3 = interface4
<1>	Interface Major Alarm1	0 = Pass, 1 = Fail Bit 0 = Interface Test Bit 1 - 7 = Spare
<1>	Interface Minor Alarm1 Status	0 = Pass, 1 = Fail Bit 0 = Interface FIFO full Bit 1 = Interface FIFO empty Bit 2 = PLL lock Bit 3 = Interface data activity detect Bit 4 = Interface clock activity detect Bit 5 - 7 = Spare
<1>	Interface Latched Major Alarm1 Status	0 = Pass, 1 = Fail Bit 0 = Interface Test Bit 1 - 7 = Spare
<1>	Interface Latched	0 = Pass, 1 = Fail

	Minor Alarm1 Status	Bit 0 = Interface FIFO full Bit 1 = Interface FIFO empty Bit 2 = PLL lock Bit 3 = Interface data activity detect Bit 4 = Interface clock activity detect Bit 5 - 7 = Spare
<1>	Interface Card	0 = None 1 = ASI/AASI 2 = ASIS 3 = NASI 4 = T3E3 5 = T1E1 6 = DSO 7 = PAR 8 = OC3 9 = HSSI 10 = SMPTE 11 = P10BaseT 12 = T2E2
<1>	Reserved	Spare

Opcode: <0x2161> Query selected Rx interface configuration

Command Data Field 1 Byte		
<1>	Selected interface number	0 = interface1 1 = interface2 2 = interface3 3 = interface4
Query Response		
<1>	Selected interface number	0 = interface1 1 = interface2 2 = interface3 3 = interface4
<4>	Interface PID	0 - 8192
<4>	Interface Data Rate	1000000 - 200000000
<1>	Interface Control	0 = Disable, 1 = Enable
<1>	Interface Type	0 = ASI 1 = AASI 2 = T3 DS3 3 = E3 4 = STS1 5 = T1 DS1 6 = E1 7 = DS0x8 8 = DS0x7+A 9 = Par DVB 10 = Par M2P 11 = OC3 12 = STM1 13 = HSSI

		14 = SMPTE19 15 = SMPTE 38 16 = P 10BaseT 17 = E2 UNBAL 18 = T2 UNBAL 19 = T2 BAL 20 = DS0 APC
<1>	Interface Sub Type	Reserved, selects the Rx interface sub-type
<1>	Interface Clock Source	0 = Rx Clk 1 = Ext BNC 2 = Ext Bal 3 = Internal Clk
<1>	Interface Clock Frequency	0 = 2.048 MHz 1 = 5.0 MHz 2 = 10.0 MHz 3 = Data Rate
<1>	Interface Framing	0 = unframed 1 = MPEG 188 2 = MPEG 204 3 = Null 188 2 = Null 204
<1>	Interface Volume	0 - 255
<1>	Interface Clock Polarity	0 = normal 1 = inverted
<1>	Interface Data Polarity	0 = normal, 1 = inverted
<1>	Reserved	Spare
<1>	Interface Terrestrial Loopback	0 = disable, 1 = enable
<1>	Interface PRBS	0 = normal 1 = prbs_23 2 = prbs_23m 3 = prbs_15 4 = prbs_15m (Not Yet Implemented)
<1>	Interface Major Alarm1 Mask	0 = Mask, 1 = Allow Bit 0 = Interface Test Bit 1 - 7 = Spare
<1>	Interface Minor Alarm1 Mask	0 = Mask, 1 = Allow Bit 0 = Interface FIFO full Bit 1 = Interface FIFO empty Bit 2 = PLL lock Bit 3 = Interface data activity detect Bit 4 = Interface clock activity detect

	Bit 5 - 7 = Spare
--	-------------------

Opcode: <0x2162> Query selected Rx interface configuration and status

Command Data Field 1 Byte		
<1>	Selected interface number	0 = interface1 1 = interface2 2 = interface3 3 = interface4
Query Response		
<1>	Selected interface number	0 = interface1 1 = interface2 2 = interface3 3 = interface4
<1>	Number of nonvol bytes* <i>* M&C developers MUST use this number of nonvolatile bytes to index into the selected interface status area. The nonvolatile data might grow with future firmware revisions. Refer to discussion on forward/backward compatibility.</i>	Number of nonvol bytes for selected interface
<4>	Interface PID	0 - 8192
<4>	Interface Data Rate	1000000 - 50000000
<1>	Interface Control	0 = Disable, 1 = Enable
<1>	Interface Type	0 = ASI 1 = AASI 2 = T3 DS3 3 = E3 4 = STS1 5 = T1 DS1 6 = E1 7 = DS0x8 8 = DS0x7+A 9 = Par DVB 10 = Par M2P 11 = OC3 12 = STM1 13 = HSSI 14 = SMPTE 19 15 = SMPTE 38 16 = P 10BaseT 17 = E2 UNBAL 18 = T2 UNBAL 19 = T2 BAL

		20 = DS0 APC
<1>	Interface Sub Type	Reserved, selects the Rx interface sub-type
<1>	Interface Clock Source	0 = Rx Clk 1 = Ext BNC 2 = Ext Bal 3 = Internal Clk
<1>	Interface Clock Frequency	0 = 2.048 MHz 1 = 5.0 MHz 2 = 10.0 MHz 3 = Data Rate
<1>	Interface Framing	0 = unframed 1 = MPEG 188 2 = MPEG 204 3 = Null 188 4 = Null 204
<1>	Interface Volume	0 – 255
<1>	Interface Clock Polarity	0 = normal, 1 = inverted, 2 = no auto
<1>	Interface Data Polarity	0 = normal, 1 = inverted
<1>	Reserved	Spare
<1>	Interface	0 = disable, 1 = enable
<1>	Terrestrial Loopback Interface PRBS	0 = normal 1 = prbs_23 2 = prbs_23m 3 = prbs_15 4 = prbs_15m (Not Yet Implemented)
<1>	Interface Major Alarm1 Mask	0 = Mask, 1 = Allow Bit 0 = Interface Test Bit 1 - 7 = Spare
<1>	Interface Minor Alarm1 Mask	0 = Mask, 1 = Allow Bit 0 = Interface FIFO full Bit 1 = Interface FIFO empty Bit 2 = PLL lock Bit 3 = Interface data activity detect Bit 4 = Interface clock activity detect Bits 5 - 7 = Spare
Status Bytes		
<1>	Interface Major Alarm1 Status	0 = Pass, 1 = Fail Bit 0 = Interface Test Bit 1 - 7 = Spare
<1>	Interface Minor Alarm1 Status	0 = Pass, 1 = Fail Bit 0 = Interface FIFO full

		Bit 1 = Interface FIFO empty Bit 2 = PLL lock Bit 3 = Interface data activity detect Bit 4 = Interface clock activity detect Bit 5 - 7 = Spare
<1>	Interface Latched Major Alarm1 Status	0 = Pass, 1 = Fail Bit 0 = Interface Test Bit 1 - 7 = Spare
<1>	Interface Latched Minor Alarm1 Status	0 = Pass, 1 = Fail Bit 0 = Interface FIFO full Bit 1 = Interface FIFO empty Bit 2 = PLL lock Bit 3 = Interface data activity detect Bit 4 = Interface clock activity detect Bit 5 - 7 = Spare
<1>	Interface Card	0 = None 1 = ASI/AASI 2 = ASIS 3 = NASI 4 = T3E3 5 = T1E1 6 = DSO 7 = PAR 8 = OC3 9 = HSSI 10 = SMPTE 11 = P10BaseT 12 = T2E2
<1>	Reserved	Spare

Opcode: <0x2163> Query selected Rx interface jitter control

Command Data Field 1 Byte		
<1>	Selected interface number	0 = interface1 1 = interface2 2 = interface3 3 = interface4
Query Response		
<1>	Selected interface number	0 = interface1 1 = interface2 2 = interface3 3 = interface4
<1>	Jitter Control	0 = Inch 1 = Slow 2 = Medium 3 = Fast 4 = Stamp2 5 = Stamp3

Opcode: <0x2164> Query selected Rx interface byte gap

Command Data Field 1 Byte		
---------------------------	--	--

<1>	Selected interface number	0 = interface1 1 = interface2 2 = interface3 3 = interface4
Query Response		
<1>	Selected interface number	0 = interface1 1 = interface2 2 = interface3 3 = interface4
<1>	Byte Gap	0 = Burst Mode, 1..255 = Byte Gap

Opcode: <0x2201> Command control mode

Command Data		
<1>	Mode	0 = Front Panel 1 = Terminal 2 = Computer 3 = Ethernet

Opcode: <0x2204> Command set time

Command Data		
<1>	Hour	0 - 23
<1>	Minute	0 - 59
<1>	Second	0 - 59

Opcode: <0x2205> Command set date

Command Data		
<1>	Year	0 - 99
<1>	Month	0 - 11
<1>	Day	0 - 30

Opcode: <0x2206> Command set time and date

Command Data		
<1>	Year	0 - 99
<1>	Month	0 - 11
<1>	Day	0 - 30
<1>	Hour	0 - 23
<1>	Minute	0 - 59
<1>	Second	0 - 59

Opcode: <0x2207> Command clear latched alarms

No Command Data		
------------------------	--	--

Opcode: <0x2208> Command set common alarm mask

Command Data		
<1>	Common Alarm1 Mask	0 = Mask, 1 = Allow Bit 0 = Glue Logic FPGA Fail Bit 1 = Test FPGA Fail Bits 2 – 7 = Spare
<1>	Common Alarm2 Mask	0 = Mask, 1 = Allow Bit 0 – 7 = Spare

Opcode: <0x2209> Command set last rate control

Command Data		
<1>	Last Rate Control	0 = Symbol 1 = Data 2 = Auto

Opcode: <0x220A> Command frequency plan

Command Data		
<1>	Frequency Plan	0 = Auto, 1 = User

Opcode: <0x220B> Command user mode

Command Data		
<1>	User Mode	0 = Reserved 1 = All Access 2 = Level 1 3 = Level 2 Note: Higher user levels restrict access to system control parameters but allow higher levels of automation

Opcode: <0x220C> Command mux loopback

Command Data		
<1>	Mux Loopback	0 = Normal, 1 = Mux/Dmx Loop, 2 = Mux/Dmx LVDS, 3 = Modem LVDS, 4 = Repeater Note: This command is not valid if the MM200 is in Repeater Mode.

Opcode: <0x220D> Command repeater mode

Command Data		
<1>	Repeater Mode	0 = Off, 1 = On

Opcode: <0x2240> Command modulator frequency

Command Data		
<4>	IF Frequency	50000000 - 90000000

Opcode: <0x2241> Command modulator data rate

Command Data		
<4>	Data Rate	70000000 - 200000000

Opcode: <0x2242> Command modulator symbol rate

Command Data		
<4>	Symbol Rate	3500000 - 28000000

Opcode: <0x2244> Command modulator modulation

Command Data		
<1>	Modulation	0 = qam4 1 = qam16 2 = qam32 3 = qam64 4 = qam128 5 = qam256

Opcode: <0x2245> Command modulator spectrum

Command Data		
<1>	Spectrum	0 = normal, 1 = inverted

Opcode: <0x224E> Command modulator alarm mask

Command Data		
<1>	Major Alarm1 Mask	0 = Mask, 1 = Allow Bit 0 = Glue Logic FPGA Fail Bit 1 = Data FPGA Fail Bits 2 – 7 = Spare
<1>	Major Alarm2 Mask	0 = Mask, 1 = Allow Bits 0 – 7 = Spare
<1>	Minor Alarm1 Mask	0 = Mask, 1 = Allow Bit 0 = Tx clock activity detect Bit 1 = Tx data activity detect Bit 2 = Frame Lock detect Bit 3 – 7 = Spare
<1>	Minor Alarm2 Mask	0 = Mask, 1 = Allow Bits 0 – 7 = Spare

Opcode: <0x224F> Command modulator PRBS

Command Data		
<1>	PRBS	0 = normal 1 = prbs_23 2 = prbs_23m 3 = prbs_15 4 = prbs_15m

Opcode: <0x2253> Command modulator Tx power

Command Data		
<4>	Tx Power	-250 to 0, implied decimal point

Opcode: <0x2254> Command modulator carrier control

Command Data		
<1>	Carrier Control	0 = disable, 1 = enable

Opcode: <0x2255> Command modulator carrier mode

Command Data		
<1>	Carrier Mode	0 = normal 1 = CW 2 = offset 1Hz 3 = 100KHz 4 = 3.5MHz 5 = sweep up 6 = sweep down

Opcode: <0x2258> Command modulator IF separation

Command Data		
<1>	IF Separation	100 - 150%

Opcode: <0x2259> Command modulator channel setting

Command Data		
<1>	Channel Setting	0 = auto 1 = one 2 = two 3 = three 4 = four 5 = debug

Opcode: <0x225A> Command modulator user frequencies

Command Data		
<4>	Frequency 1	50 MHz – 90 MHz
<4>	Frequency 2	50 MHz – 90 MHz
<4>	Frequency 3	50 MHz – 90 MHz
<4>	Frequency 4	50 MHz – 90 MHz

Opcode: <0x225B> Command modulator bandwidth

Command Data		
<4>	Bandwidth	Available bandwidth Note: Command is only allowed in Level 2 User Mode. Along with the selected interfaces, and the number of channels, the modem calculates all relevant system parameters optimizing for robustness (minimizing modulation).

Opcode: <0x2270> Command selected modulator channel configuration

Command Data		
<1>	Selected channel number	0 = channel1 1 = channel2 2 = channel3 3 = channel4
<1>	Channel Major Alarm Mask	0 = Mask, 1 = Allow Bit 0 = Mod daughter board FPGA status Bit 1 = RF PLL lock detect status

<1>	Channel Minor Alarm Mask	Bit 2 - 7 = Spare 0 = Mask, 1 = Allow Bit 0 = Loop lock status Bit 1 = FEC lock status Bit 2 = FIFO full status Bit 3 = FIFO empty status Bit 4 = FIFO active status Bit 5 - 7 = Spare
-----	--------------------------	---

Opcode: <0x2271> Command selected Tx interface configuration

Command Data		
<1>	Selected interface number	0 = interface1 1 = interface2 2 = interface3 3 = interface4
<4>	Interface PID	0 - 8192
<4>	Interface Data Rate	1000000 - 200000000
<1>	Interface Control	0 = Disable, 1 = Enable
<1>	Interface Type	0 = ASI 1 = AASI 2 = T3 DS3 3 = E3 4 = STS1 5 = T1 DS1 6 = E1 7 = DS0x8 8 = DS0x7+A 9 = Par DVB 10 = Par M2P 11 = OC3 12 = STM1 13 = HSSI 14 = SMPTE 19 15 = SMPTE 38 16 = P 10BaseT 17 = E2 UNBAL 18 = T2 UNBAL 19 = T2 BAL 20 = DS0 APC
<1>	Interface Sub Type	Reserved, selects the Tx interface sub-type
<1>	Interface Framing	0 = unframed 1 = MPEG 188 2 = MPEG 204
<1>	Interface Volume	0 - 255
<1>	Interface Clock Polarity	0 = normal, 1 = inverted, 2 = auto

<1>	Interface Data Polarity	0 = normal, 1 = inverted
<1>	Interface Baseband Loopback	0 = disable, 1 = enable
<1>	Reserved	Spare
<1>	Interface PRBS	0 = normal 1 = prbs_23 2 = prbs_23m 3 = prbs_15 4 = prbs_15m (Not Yet Implemented)
<1>	Interface Major Alarm1 Mask	0 = Mask, 1 = Allow Bit 0 = Interface Test Bit 1 - 7 = Spare
<1>	Interface Minor Alarm1	Mask 0 = Mask, 1 = Allow Bit 0 = Interface FIFO full Bit 1 = Interface FIFO empty Bit 2 = PLL lock Bit 3 = Interface data activity detect Bit 4 = Interface clock activity detect Bit 5 = Interface Tx input framing valid, added for AASI Bit 6 = Interface signal loss, valid for some interfaces Bit 7 = Spare

Opcode: <0x2272> Command selected Tx interface jitter control

Command Data		
<1>	Selected interface number	0 = interface1 1 = interface2 2 = interface3 3 = interface4
<1>	Jitter Control	0 = Normal, 1 = Stamp2, 2 = Stamp3

Opcode: <0x2280> Command demodulator frequency

Command Data		
<4>	IF Frequency	50000000 - 90000000

Opcode: <0x2281> Command demodulator data rate

Command Data		
<4>	Data Rate	70000000 - 200000000

Opcode: <0x2282> Command demodulator symbol rate

Command Data		
<4>	Symbol Rate	3500000 - 28000000

Opcode: <0x2284> Command demodulator demodulation

Command Data		
--------------	--	--

<1>	Demodulation	0 = qam4 1 = qam16 2 = qam32 3 = qam64 4 = qam128 5 = qam256
-----	--------------	---

Opcode: <0x2285> Command demodulator spectrum

Command Data		
<1>	Spectrum	0 = normal, 1 = inverted

Opcode: <0x228E> Command demodulator alarm mask

Command Data		
<1>	Major Alarm1 Mask	0 = Mask, 1 = Allow Bit 0 = Glue Logic FPGA Fail Bit 1 = Data FPGA Fail Bit 2 = Signal Lock Detect Bit 3 = Sync Lock Detect Bit 4 = Deframer clock PLL lock detect Bit 5 = Diversity FPGA fail Bits 6 – 7 = Spare
<1>	Major Alarm2 Mask	0 = Mask, 1 = Allow Bits 0 – 7 = Spare
<1>	Minor Alarm1 Mask	0 = Mask, 1 = Allow Bits 0 – 7 = Spare
<1>	Minor Alarm2 Mask	0 = Mask, 1 = Allow Bits 0 – 7 = Spare

Opcode: <0x2298> Command demodulator IF separation

Command Data		
<1>	IF Separation	120 - 150

Opcode: <0x2299> Command demodulator channel setting

Command Data		
<1>	Channel Setting	0 = auto 1 = one 2 = two 3 = three 4 = four 5 = debug

Opcode: <0x229A> Command demodulator IF frequencies

Command Data		
<4>	Frequency 1	50 MHz – 90 MHz
<4>	Frequency 2	50 MHz – 90 MHz
<4>	Frequency 3	50 MHz – 90 MHz
<4>	Frequency 4	50 MHz – 90 MHz

Opcode: <0x229B> Command demodulator bandwidth

Command Data		
<4>	Bandwidth	Available bandwidth Note: Command is only allowed in Level 2 User Mode. Along with the selected interfaces, and the number of channels, the modem calculates all relevant system parameters optimizing for robustness (minimizing modulation).

Opcode: <0x229C> Command demodulator acquisition

Command Data		
<2>	Acquisition Bandwidth	50 – 400 kHz, 1 kHz steps
<1>	Acquisition Control	0 = Off, 1 = Acquire
<1>	Acquisition Delay	10 – 255 sec, 1 sec steps
<1>	Acquisition Step	10 – 100 kHz, 1 kHz steps
<1>	Tracking Step	10 – 100 Hz, 1 Hz steps
<1>	Re-acquisition Delay	10 – 255 sec, 1 sec steps

Opcode: <0x229D> Command demodulator diversity mode

Command Data		
<1>	Diversity Mode	0 = Disable, 1 = Auto, 2 = Force A, 3 = Force B

Opcode: <0x229E> Command demodulator clear BER channels

Command Data		
<1>	BER Channel to Clear	0 = Clear all channels 1 = Clear channel 1 BER 2 = Clear channel 2 BER 3 = Clear channel 3 BER 4 = Clear channel 4 BER

Opcode: <0x22B0> Command selected demodulator channel configuration

Command Data		
<1>	Selected channel Number	0 = channel1 1 = channel2 2 = channel3 3 = channel4
<1>	Channel Major Alarm Mask	0 = Mask, 1 = Allow Bit 0 = Demod daughter board FPGA status Bit 1 = RF PLL lock detect status Bits 2 - 7 = Spare
<1>	Channel Minor Alarm Mask	0 = Mask, 1 = Allow Bit 0 = QAM lock status Bit 1 = FEC lock status Bit 2 = FIFO full status Bit 3 = FIFO empty status

		Bit 4 = Sync lock status Bit 5 = FIFO reload Status Bit 6 = FIFO pos status Bit 7 = Track fault status
--	--	---

Opcode: <0x22B1> Command selected Rx interface configuration

Command Data		
<1>	Selected interface number	0 = interface1 1 = interface2 2 = interface3 3 = interface4
<4>	Interface PID	0 - 8192
<4>	Interface Data Rate	1000000 - 200000000
<1>	Interface Control	0 = Disable, 1 = Enable
<1>	Interface Type	0 = ASI 1 = AASI 2 = T3 DS3 3 = E3 4 = STS1 5 = T1 DS1 6 = E1 7 = DS0x8 8 = DS0x7+A 9 = Par DVB 10 = Par M2P 11 = OC3 12 = STM1 13 = HSSI 14 = SMPTE 19 15 = SMPTE 38 16 = P 10BaseT 17 = E2 UNBAL 18 = T2 UNBAL 19 = T2 BAL 20 = DS0 APC
<1>	Interface Sub Type	Reserved, selects the Rx interface sub-type
<1>	Interface Clock Source	0 = Rx Clk 1 = Ext BNC 2 = Ext Bal 3 = Internal 4 = Tx Clk
<1>	Interface Clock Frequency	0 = 2.048 MHz 1 = 5.0 MHz 2 = 10.0 MHz 3 = Data Rate
<1>	Interface	0 = unframed

	Framing	1 = MPEG 188 2 = MPEG 204 3 = Null 188 4 = Null 204
<1>	Interface Volume	0 - 255
<1>	Interface Clock Polarity	0 = normal 1 = inverted
<1>	Interface Data Polarity	0 = normal, 1 = inverted
<1>	Reserved	Spare
<1>	Interface Terrestrial Loopback	0 = disable, 1 = enable
<1>	Interface PRBS	0 = normal 1 = prbs_23 2 = prbs_23m 3 = prbs_15 4 = prbs_15m (Not Yet Implemented)
<1>	Interface Major Alarm1 Mask	0 = Mask, 1 = Allow Bit 0 = Interface Test Bit 1 - 7 = Spare
<1>	Interface Minor Alarm1 Mask	0 = Mask, 1 = Allow Bit 0 = Interface FIFO full Bit 1 = Interface FIFO empty Bit 2 = PLL lock Bit 3 = Interface data activity detect Bit 4 = Interface clock activity detect Bits 5 - 7 = Spare

Opcode: <0x22B2> Command selected Rx interface jitter control

Command Data		
<1>	Selected interface number	0 = interface1 1 = interface2 2 = interface3 3 = interface4
<1>	Jitter Control	0 = Inch 1 = Slow 2 = Medium 3 = Fast 4 = Stamp2 5 = Stamp3

Opcode: <0x22B3> Command selected Rx interface byte gap

Command Data		
<1>	Selected interface number	0 = interface1 1 = interface2 2 = interface3

<1>	Byte Gap	3 = interface4 0 = Burst Mode, 1..255 = Byte Gap
-----	----------	---



SNMP MIB**B**

MM200-MIB DEFINITIONS ::= BEGIN

IMPORTS

enterprises
 FROM RFC1155-SMI
 MODULE-IDENTITY, OBJECT-TYPE
 FROM SNMPv2-SMI;

mm200 MODULE-IDENTITY

LAST-UPDATED "200611011000Z"
 ORGANIZATION "Radyne Inc. Inc."
 CONTACT-INFO
 "Customer Service
 Postal: Radyne, Inc. - Phoenix.
 3138 E. Elwood Street
 Phoenix, AZ 85034
 USA

 Tel: (602) 437-9620
 Fax: (602) 437-4811

 Email: radyne-custservice@radn.com"

DESCRIPTION

"Radyne MM200 MIB module."

REVISION "200109051000Z"

DESCRIPTION "Initial version of the Radyne MM200
 MIB module. This is a PRILIMINARY document whose contents
 are subject to change without prior notice. MM200 MIB
 Object Identifiers description. The private enterprise
 number 2591 is a unique identifier assigned to Radyne
 by the Internet Assigned Numbers Authority (IANA).
 This number is used to uniquely define vendor specific
 information such as private MIBs."

::= { radyne 11 }

-- groups in Radyne specific MIB

radyne	OBJECT IDENTIFIER ::= { enterprises 2591 }
mm200MIBObjects	OBJECT IDENTIFIER ::= { mm200 1 }
radMM200ModNVStatus	OBJECT IDENTIFIER ::= { mm200MIBObjects 1 }
radMM200ModStatus	OBJECT IDENTIFIER ::= { mm200MIBObjects 2 }
radMM200DemodNVStatus	OBJECT IDENTIFIER ::= { mm200MIBObjects 7 }
radMM200DemodStatus	OBJECT IDENTIFIER ::= { mm200MIBObjects 8 }
radMM200CommonNVStatus	OBJECT IDENTIFIER ::= { mm200MIBObjects 13 }
radMM200CommonStatus	OBJECT IDENTIFIER ::= { mm200MIBObjects 14 }
radMM200MIBTraps	OBJECT IDENTIFIER ::= { mm200MIBObjects 15 }
mm200MIBConformance	OBJECT IDENTIFIER ::= { mm200 2 }
mm200Groups	OBJECT IDENTIFIER ::= { mm200MIBConformance 1 }
mm200AgentCapabilities	OBJECT IDENTIFIER ::= { mm200MIBConformance 2 }

```

-----
-- Textual Conventions

ControlType ::= TEXTUAL-CONVENTION
    STATUS current
    DESCRIPTION "Represents a boolean control value."
    SYNTAX INTEGER { disable(1), enable(2) }

InversionType ::= TEXTUAL-CONVENTION
    STATUS current
    DESCRIPTION "Represents a boolean inversion value."
    SYNTAX INTEGER { normal(1), inverted(2) }

AlarmByteType ::= TEXTUAL-CONVENTION
    STATUS current
    DESCRIPTION "Represents a one byte integer value. Limits are 0 to 255"
    SYNTAX INTEGER (0..255)

-----
-- MM200 modulator non-volatile status information.

radMM200TxCarrierControl OBJECT-TYPE
    SYNTAX INTEGER {
        off(1),
        on(2)
    }
    MAX-ACCESS read-write
    STATUS current
    DESCRIPTION
        "Turns carrier on and off"
    ::= { radMM200ModNVStatus 1 }

radMM200TxTransmitPower OBJECT-TYPE
    SYNTAX INTEGER (-200..0)
    MAX-ACCESS read-write
    STATUS current
    DESCRIPTION
        "Selects the Tx power level in dBm from +0.0 to -20.0. There is an
        implied decimal point. For example a value of -39 represents a
        transmit power level of -3.9 dBm."
    ::= { radMM200ModNVStatus 2 }

radMM200TxIFFrequency OBJECT-TYPE
    SYNTAX INTEGER (50000000..90000000)
    MAX-ACCESS read-write
    STATUS current
    DESCRIPTION
        "Selects IF frequency in Hz. This is the center frequency of the
        aggregate; the edge frequency, however, is dependent on the number
        of channels, symbol rate, and spacing. The frequency range of the
        MM200 is 50MHz to 90MHz."
    ::= { radMM200ModNVStatus 3 }

radMM200TxIFUser1Frequency OBJECT-TYPE
    SYNTAX INTEGER (50000000..90000000)
    MAX-ACCESS read-write
    STATUS current
    DESCRIPTION
        "Selects IF user 1 frequency in Hz."
    ::= { radMM200ModNVStatus 4 }

radMM200TxIFUser2Frequency OBJECT-TYPE
    SYNTAX INTEGER (50000000..90000000)
    MAX-ACCESS read-write
    STATUS current

```

```

DESCRIPTION
    "Selects IF user 2 frequency in Hz."
 ::= { radMM200ModNVStatus 5 }

radMM200TxIFUser3Frequency OBJECT-TYPE
    SYNTAX INTEGER (50000000..90000000)
    MAX-ACCESS    read-write
    STATUS current
    DESCRIPTION
        "Selects IF user 3 frequency in Hz."
 ::= { radMM200ModNVStatus 6 }

radMM200TxIFUser4Frequency OBJECT-TYPE
    SYNTAX INTEGER (50000000..90000000)
    MAX-ACCESS    read-write
    STATUS current
    DESCRIPTION
        "Selects IF user 4 frequency in Hz."
 ::= { radMM200ModNVStatus 7 }

radMM200TxIFSeperation OBJECT-TYPE
    SYNTAX INTEGER (100..150)
    MAX-ACCESS    read-write
    STATUS current
    DESCRIPTION
        "Selects IF frequency separation in percent. It is the additional
        bandwidth percentage the carrier will cover over the original symbol
        rate. The range is 100% to 150%."
 ::= { radMM200ModNVStatus 8 }

radMM200TxDataRate OBJECT-TYPE
    SYNTAX INTEGER (7000000..200000000)
    MAX-ACCESS    read-write
    STATUS current
    DESCRIPTION
        "Selects the data rate in BPS. The data rate is variable from 7 Mbps
        to 200 Mbps."
 ::= { radMM200ModNVStatus 9 }

radMM200TxSymbolRate OBJECT-TYPE
    SYNTAX INTEGER (3500000..28000000)
    MAX-ACCESS    read-write
    STATUS current
    DESCRIPTION
        "Selects the symbol rate in SPS. The symbol rate is variable from 3.5Msp
to 28Msp."
 ::= { radMM200ModNVStatus 10 }

radMM200TxModulation OBJECT-TYPE
    SYNTAX INTEGER {
        qam4(1),
        qam16(2),
        qam32(3),
        qam64(4),
        qam128(5),
        qam256(6)
    }
    MAX-ACCESS    read-write
    STATUS current
    DESCRIPTION
        "Selects the QAM modulation type."
 ::= { radMM200ModNVStatus 11 }

radMM200TxSpectrum OBJECT-TYPE
    SYNTAX InversionType
    MAX-ACCESS    read-write
    STATUS current

```

```

DESCRIPTION
    "Inverts the direction of rotation for the modulation."
    ::= { radMM200ModNVStatus 12 }

radMM200TxCarrierMode OBJECT-TYPE
    SYNTAX INTEGER {
        normal(1),
        cw(2),
        offset1hz(3),
        khz100(4),
        mhz35(5),
        sweepUp(6),
        sweepDown(7)
    }
    MAX-ACCESS    read-write
    STATUS current
    DESCRIPTION
    "Normal sets the carrier to normal
    CW causes the modulator to output pure carrier
    Offset 1Hz
    100 KHz
    3.5 MHz
    Sweep up
    Sweep down"
    ::= { radMM200ModNVStatus 13 }

radMM200TxChannelSetting OBJECT-TYPE
    SYNTAX INTEGER {
        oneChannel(2),
        twoChannel(3),
        threeChannel(4),
        fourChannel(5)
    }
    MAX-ACCESS    read-write
    STATUS current
    DESCRIPTION
    "Selects the total number of channels in the MM200.
    Automatic selection allows the MM200 to use the
    maximum number of channels."
    ::= { radMM200ModNVStatus 14 }

radMM200TxMajorAlarm1Mask OBJECT-TYPE
    SYNTAX AlarmByteType
    MAX-ACCESS    read-write
    STATUS current
    DESCRIPTION
    "Major Alarm 1 mask:
    Bit 0 = Glue logic FPGA fail
    Bit 1 = Data FPGA fail
    Bit 2-7 = Spares
    0 = Mask, 1 = Allow"
    ::= { radMM200ModNVStatus 15 }

radMM200TxMajorAlarm2Mask OBJECT-TYPE
    SYNTAX AlarmByteType
    MAX-ACCESS    read-write
    STATUS current
    DESCRIPTION
    "Major Alarm 2 mask:
    Bit 0-7 = Spares
    0 = Mask, 1 = Allow"
    ::= { radMM200ModNVStatus 16 }

radMM200TxMinorAlarm1Mask OBJECT-TYPE
    SYNTAX AlarmByteType
    MAX-ACCESS    read-write
    STATUS current

```



```

DESCRIPTION
"Minor Alarm 1 mask:
Bit 0 = Tx clock activity detect
Bit 1 = Tx data activity detect
Bit 2 = Frame lock
Bit 3 = Spare
Bit 4 = Spare
Bit 5 = Spare
Bit 6 = Spare
Bit 7 = Spare
0 = Mask, 1 = Allow"
::= { radMM200ModNVStatus 17 }

```

```

radMM200TxMinorAlarm2Mask OBJECT-TYPE
SYNTAX AlarmByteType
MAX-ACCESS read-write
STATUS current
DESCRIPTION
"Minor Alarm 2 mask:
Bit 0..7 = Spares
0 = Mask, 1 = Allow"
::= { radMM200ModNVStatus 18 }

```

```

radMM200TxPRBS OBJECT-TYPE
SYNTAX INTEGER {
normal(1),
prbs23(2),
prbs23m(3),
prbs15(4),
prbs15m(5)
}
MAX-ACCESS read-write
STATUS current
DESCRIPTION
"Selects the pseudo-random bit sequence for link
testing."
::= { radMM200ModNVStatus 19 }

```

-- MM200 modulator status information.

```

radMM200TxMajorAlarm1Status OBJECT-TYPE
SYNTAX AlarmByteType
MAX-ACCESS read-only
STATUS current
DESCRIPTION
"A bit field. On startup, the agent initializes this
to the value '00000000'B
Bit 0 = Glue logic FPGA fail
Bit 1 = Data FPGA fail
Bit 2-7 = Spares
0 = Pass, 1 = Fail"
::= { radMM200ModStatus 1 }

```

```

radMM200TxMajorAlarm2Status OBJECT-TYPE
SYNTAX AlarmByteType
MAX-ACCESS read-only
STATUS current
DESCRIPTION
"A bit field. On startup, the agent initializes this to
the value '00000000'B
Bit 0..7 = Spares
0 = Pass, 1 = Fail"
::= { radMM200ModStatus 2 }

```

```

radMM200TxMinorAlarm1Status OBJECT-TYPE
    SYNTAX AlarmByteType
    MAX-ACCESS read-only
    STATUS current
    DESCRIPTION
        "A bit field. On startup, the agent initializes this to
        the value '00000000'B
        Bit 0 = Tx clock activity detect
        Bit 1 = Tx data activity detect
        Bit 2 = Frame lock
        Bit 3 = Spare
        Bit 4 = Spare
        Bit 5 = Spare
        Bit 6 = Spare
        Bit 7 = Spare
        0 = Pass, 1 = Fail"
    ::= { radMM200ModStatus 3 }

radMM200TxMinorAlarm2Status OBJECT-TYPE
    SYNTAX AlarmByteType
    MAX-ACCESS read-only
    STATUS current
    DESCRIPTION
        "A bit field. On startup, the agent initializes this to
        the value '00000000'B
        Bit 0..7 = Spares
        0 = Pass, 1 = Fail"
    ::= { radMM200ModStatus 4 }

radMM200TxLatchedMajorAlarm1Status OBJECT-TYPE
    SYNTAX AlarmByteType
    MAX-ACCESS read-only
    STATUS current
    DESCRIPTION
        "A bit field. On startup, the agent initializes this
        to the value '00000000'B.
        Bit 0 = Glue logic FPGA fail
        Bit 1 = Data FPGA fail
        Bit 2-7 = Spares
        0 = Pass, 1 = Fail"
    ::= { radMM200ModStatus 5 }

radMM200TxLatchedMajorAlarm2Status OBJECT-TYPE
    SYNTAX AlarmByteType
    MAX-ACCESS read-only
    STATUS current
    DESCRIPTION
        "A bit field. On startup, the agent initializes this to
        the value '00000000'B.
        Bit 0..7 = Spares
        0 = Pass, 1 = Fail"
    ::= { radMM200ModStatus 6 }

radMM200TxLatchedMinorAlarm1Status OBJECT-TYPE
    SYNTAX AlarmByteType
    MAX-ACCESS read-only
    STATUS current
    DESCRIPTION
        "A bit field. On startup, the agent initializes this to
        the value '00000000'B.
        Bit 0 = Tx clock activity detect
        Bit 1 = Tx data activity detect
        Bit 2 = Frame lock
        Bit 3 = Spare
        Bit 4 = Spare
        Bit 5 = Spare
        Bit 6 = Spare
    
```

```

Bit 7 = Spare
0 = Pass, 1 = Fail"
::= { radMM200ModStatus 7 }

```

```

radMM200TxLatchedMinorAlarm2Status OBJECT-TYPE
    SYNTAX AlarmByteType
    MAX-ACCESS read-only
    STATUS current
    DESCRIPTION
        "A bit field. On startup, the agent initializes this to
        the value '00000000'B.
        Bit 0..7 = Spares
        0 = Pass, 1 = Fail"
    ::= { radMM200ModStatus 8 }

```

```

radMM200TxCarrierStatus OBJECT-TYPE
    SYNTAX INTEGER {
        off(1),
        on(2)
    }
    MAX-ACCESS read-only
    STATUS current
    DESCRIPTION
        "Shows status of the carrier, on or off"
    ::= { radMM200ModStatus 9 }

```

```

radMM200TxMaxPayload OBJECT-TYPE
    SYNTAX INTEGER (0..200000000)
    MAX-ACCESS read-only
    STATUS current
    DESCRIPTION
        "Maximum payload at current modulation."
    ::= { radMM200ModStatus 10 }

```

```

radMM200TxPercentUtilization OBJECT-TYPE
    SYNTAX INTEGER (0..65536)
    MAX-ACCESS read-only
    STATUS current
    DESCRIPTION
        "% utilization, implied decimal point.(i.e. 7985 means 79.85%"
    ::= { radMM200ModStatus 11 }

```

```

radMM200TxBandwidth OBJECT-TYPE
    SYNTAX INTEGER (0..40000000)
    MAX-ACCESS read-only
    STATUS current
    DESCRIPTION
        "Current bandwidth usage."
    ::= { radMM200ModStatus 12 }

```

```

-----
-- MM200 modulator channel non-volatile status information.

```

```

radMM200TxChannelNVStatusTable OBJECT-TYPE
    SYNTAX SEQUENCE OF RadMM200TxChannelNVStatusEntry
    MAX-ACCESS not-accessible
    STATUS mandatory
    DESCRIPTION
        "MM200 Tx channel non-volatile status Table"
    ::= { mm200MIBObjects 3 }

```

```

radMM200TxChannelNVStatusEntry OBJECT-TYPE
    SYNTAX RadMM200TxChannelNVStatusEntry
    MAX-ACCESS not-accessible
    STATUS current
    DESCRIPTION

```

```

                                "MM200 Tx channel non-volatile status structure"
INDEX { radMM200TxChannelNVIndex }
 ::= { radMM200TxChannelNVStatusTable 1 }

RadMM200TxChannelNVStatusEntry ::=
SEQUENCE {
    radMM200TxChannelNVIndex INTEGER,
    radMM200TxChannelMajorAlarmMask INTEGER,
    radMM200TxChannelMinorAlarmMask INTEGER
}

radMM200TxChannelNVIndex OBJECT-TYPE
SYNTAX INTEGER (1..4)
MAX-ACCESS read-only
STATUS current
DESCRIPTION
    "Index into the MM200 Tx channel non-volatile table."
 ::= { radMM200TxChannelNVStatusEntry 1 }

radMM200TxChannelMajorAlarmMask OBJECT-TYPE
SYNTAX AlarmByteType
MAX-ACCESS read-write
STATUS current
DESCRIPTION
    "Major Alarm mask:
    Bit 0 = Mod daughter board FPGA status
    Bit 1 = RF PLL lock detect status
    Bit 2-7 = Spares
    0 = Mask, 1 = Allow"
 ::= { radMM200TxChannelNVStatusEntry 2 }

radMM200TxChannelMinorAlarmMask OBJECT-TYPE
SYNTAX AlarmByteType
MAX-ACCESS read-write
STATUS current
DESCRIPTION
    "Minor Alarm mask:
    Bit 0 = Loop lock status
    Bit 1 = FEC lock status
    Bit 2 = FIFO full status
    Bit 3 = FIFO empty status
    Bit 4 = FIFO active
    Bit 5-7 = Spares
    0 = Mask, 1 = Allow"
 ::= { radMM200TxChannelNVStatusEntry 3 }

-----
-- MM200 modulator channel status information.

radMM200TxChannelStatusTable OBJECT-TYPE
SYNTAX SEQUENCE OF RadMM200TxChannelStatusEntry
MAX-ACCESS not-accessible
STATUS mandatory
DESCRIPTION
    "MM200 Tx channel volatile status Table"
 ::= { mm200MIBObjects 4 }

radMM200TxChannelStatusEntry OBJECT-TYPE
SYNTAX RadMM200TxChannelStatusEntry
MAX-ACCESS not-accessible
STATUS current
DESCRIPTION
    "MM200 Tx channel volatile status structure"
INDEX { radMM200TxChannelIndex }
 ::= { radMM200TxChannelStatusTable 1 }

```

```

RadMM200TxChannelStatusEntry ::=
    SEQUENCE {
        radMM200TxChannelIndex INTEGER,
        radMM200TxChannelMajorAlarmStatus INTEGER,
        radMM200TxChannelMinorAlarmStatus INTEGER,
        radMM200TxChannelLatchedMajorAlarmStatus INTEGER,
        radMM200TxChannelLatchedMinorAlarmStatus INTEGER,
        radMM200TxChannelBaudRate INTEGER,
        radMM200TxChannelBaudState INTEGER
    }

radMM200TxChannelIndex OBJECT-TYPE
    SYNTAX INTEGER (1..4)
    MAX-ACCESS read-only
    STATUS current
    DESCRIPTION
        "Index into the MM200 Tx channel volatile table."
    ::= { radMM200TxChannelStatusEntry 1 }

radMM200TxChannelMajorAlarmStatus OBJECT-TYPE
    SYNTAX AlarmByteType
    MAX-ACCESS read-only
    STATUS current
    DESCRIPTION
        "Major Alarm status:
        Bit 0 = Mod daughter board FPGA status
        Bit 1 = RF PLL lock detect status
        Bit 2-7 = Spares
        0 = PASS, 1 = FAIL"
    ::= { radMM200TxChannelStatusEntry 2 }

radMM200TxChannelMinorAlarmStatus OBJECT-TYPE
    SYNTAX AlarmByteType
    MAX-ACCESS read-only
    STATUS current
    DESCRIPTION
        "Minor Alarm status:
        Bit 0 = Loop lock status
        Bit 1 = FEC lock status
        Bit 2 = FIFO full status
        Bit 3 = FIFO empty status
        Bit 4 = FIFO active
        Bit 5-7 = Spares
        0 = PASS, 1 = FAIL"
    ::= { radMM200TxChannelStatusEntry 3 }

radMM200TxChannelLatchedMajorAlarmStatus OBJECT-TYPE
    SYNTAX AlarmByteType
    MAX-ACCESS read-only
    STATUS current
    DESCRIPTION
        "Major Alarm status:
        Bit 0 = Mod daughter board FPGA status
        Bit 1 = RF PLL lock detect status
        Bit 2-7 = Spares
        0 = PASS, 1 = FAIL"
    ::= { radMM200TxChannelStatusEntry 4 }

radMM200TxChannelLatchedMinorAlarmStatus OBJECT-TYPE
    SYNTAX AlarmByteType
    MAX-ACCESS read-only
    STATUS current
    DESCRIPTION
        "Minor Alarm status:
        Bit 0 = Loop lock status
        Bit 1 = FEC lock status
        Bit 2 = FIFO full status

```

```

Bit 3 = FIFO empty status
Bit 4 = FIFO active
Bit 5-7 = Spares
0 = PASS, 1 = FAIL"
 ::= { radMM200TxChannelStatusEntry 5 }

```

```

radMM200TxChannelBaudRate OBJECT-TYPE
  SYNTAX INTEGER (7000000..200000000)
  MAX-ACCESS read-only
  STATUS current
  DESCRIPTION
    "Tx channel baud rate"
  ::= { radMM200TxChannelStatusEntry 6 }

```

```

radMM200TxChannelBaudState OBJECT-TYPE
  SYNTAX INTEGER {
    clockSourcing(1),
    outOfLock(2),
    losingLock(3),
    acquiring(4),
    locked(5),
    tooSlow(6),
    tooFast(7),
    searchingUp(8),
    searchingDown(9)
  }
  MAX-ACCESS read-only
  STATUS current
  DESCRIPTION
    "Tx channel baud state"
  ::= { radMM200TxChannelStatusEntry 7 }

```

 -- MM200 modulator interface non-volatile status information.

```

radMM200TxInterfaceNVStatusTable OBJECT-TYPE
  SYNTAX SEQUENCE OF RadMM200TxInterfaceNVStatusEntry
  MAX-ACCESS not-accessible
  STATUS mandatory
  DESCRIPTION
    "MM200 Tx interface non-volatile status Table"
  ::= { mm200MIBObjects 5 }

```

```

radMM200TxInterfaceNVStatusEntry OBJECT-TYPE
  SYNTAX RadMM200TxInterfaceNVStatusEntry
  MAX-ACCESS not-accessible
  STATUS current
  DESCRIPTION
    "MM200 Tx interface non-volatile status structure"
  INDEX { radMM200TxInterfaceNVIndex }
  ::= { radMM200TxInterfaceNVStatusTable 1 }

```

```

RadMM200TxInterfaceNVStatusEntry ::=
  SEQUENCE {
    radMM200TxInterfaceNVIndex INTEGER,
    radMM200TxInterfacePID INTEGER,
    radMM200TxInterfaceDataRate INTEGER,
    radMM200TxInterfaceControl INTEGER,
    radMM200TxInterfaceType INTEGER,
    radMM200TxInterfaceSubType INTEGER,
    radMM200TxInterfaceFraming INTEGER,
    radMM200TxInterfaceVolume INTEGER,
    radMM200TxInterfaceClockPolarity INTEGER,
    radMM200TxInterfaceDataInvert INTEGER,
    radMM200TxInterfaceBasebandLoopback INTEGER,
    radMM200TxInterfacePRBS INTEGER,

```

```

        radMM200TxInterfaceMajorAlarmMask INTEGER,
        radMM200TxInterfaceMinorAlarmMask INTEGER,
        radMM200TxInterfaceJitterControl INTEGER
    }

radMM200TxInterfaceNVIndex OBJECT-TYPE
    SYNTAX INTEGER (1..4)
    MAX-ACCESS read-only
    STATUS current
    DESCRIPTION
        "Index into the MM200 Tx interface on-volatile table."
    ::= { radMM200TxInterfaceNVStatusEntry 1 }

radMM200TxInterfacePID OBJECT-TYPE
    SYNTAX INTEGER (0..8192)
    MAX-ACCESS read-write
    STATUS current
    DESCRIPTION
        "Selects the interface Program Id. If not in 188 byte
        framing mode (unframed), this PID steers the packet to
        the appropriate interface. In the MM200, only one
        framed interface is allowed and its packets are sent in
        the clear, without modifications. The Null PID and the PIDs
        of the unframed interfaces should be unique. All packets
        PIDs not equal to these will be sent to the framed
        interface."
    ::= { radMM200TxInterfaceNVStatusEntry 2 }

radMM200TxInterfaceDataRate OBJECT-TYPE
    SYNTAX INTEGER (64000..200000000)
    MAX-ACCESS read-write
    STATUS current
    DESCRIPTION
        "Selects the data rate in BPS of the individual interfaces.
        The data rate is T3, E3, or STS1 for G.703
        155.52M BPS for OC3 and STM1
        1.544M BPS for T1
        2.048M BPS for E1
        Variable for parallel and ASI
        64K BPS for 8 channel DS0
        The range is between 64K to 200M BPS"
    ::= { radMM200TxInterfaceNVStatusEntry 3 }

radMM200TxInterfaceControl OBJECT-TYPE
    SYNTAX ControlType
    MAX-ACCESS read-write
    STATUS current
    DESCRIPTION
        "Controls the Tx interface."
    ::= { radMM200TxInterfaceNVStatusEntry 4 }

radMM200TxInterfaceType OBJECT-TYPE
    SYNTAX INTEGER {
        asi(1)
        aasi(2)
        t3(3),
        e3(4),
        sts1(5),
        t1(6),
        e1(7),
        ds0x8(8),
        ds0x7A(9),
        parallelDVB(10),
        parallelM2P(11),
        oc3(12),
        stm1(13),
        hssi(14),
    }

```

```

        smpt19(15)
        smpt38(16)
    }
    MAX-ACCESS read-write
    STATUS current
    DESCRIPTION
    "Selects the Tx interface type."
    ::= { radMM200TxInterfaceNVStatusEntry 5 }

radMM200TxInterfaceSubType OBJECT-TYPE
    SYNTAX INTEGER {
        spare(1)
    }
    MAX-ACCESS read-write
    STATUS current
    DESCRIPTION
    "Selects the Tx interface sub-type."
    ::= { radMM200TxInterfaceNVStatusEntry 6 }

radMM200TxInterfaceFraming OBJECT-TYPE
    SYNTAX INTEGER {
        unframed(1),
        mpeg188(2),
        mpeg204(3)
    }
    MAX-ACCESS read-write
    STATUS current
    DESCRIPTION
    "Selects Unframed (184 Byte proprietary packet),
    MPEG Sync Byte and MPEG Sync Byte plus ReedSolomon."
    ::= { radMM200TxInterfaceNVStatusEntry 7 }

radMM200TxInterfaceVolume OBJECT-TYPE
    SYNTAX INTEGER (0..255)
    MAX-ACCESS read-write
    STATUS current
    DESCRIPTION
    "Sets the volume on the audio channel on the DS0
    interfaces"
    ::= { radMM200TxInterfaceNVStatusEntry 8 }

radMM200TxInterfaceClockPolarity OBJECT-TYPE
    SYNTAX INTEGER {
        normal(1),
        inverted(2)
    }
    MAX-ACCESS read-write
    STATUS current
    DESCRIPTION
    "Selects clock polarity for Tx terrestrial clock
    relative to Tx data."
    ::= { radMM200TxInterfaceNVStatusEntry 9 }

radMM200TxInterfaceDataInvert OBJECT-TYPE
    SYNTAX InversionType
    MAX-ACCESS read-write
    STATUS current
    DESCRIPTION
    "Selects data polarity"
    ::= { radMM200TxInterfaceNVStatusEntry 10 }

radMM200TxInterfaceBasebandLoopback OBJECT-TYPE
    SYNTAX ControlType
    MAX-ACCESS read-write
    STATUS current
    DESCRIPTION
    "Enables or disables Tx Interface Baseband Loopback."

```



```

 ::= { radMM200TxInterfaceNVStatusEntry 11 }

radMM200TxInterfacePRBS OBJECT-TYPE
    SYNTAX INTEGER {
        normal(1),
        ones(2),
        pat001(3),
        prbs2047(4)
    }
    MAX-ACCESS    read-write
    STATUS current
    DESCRIPTION
    "Selects the pseudo-random bit sequence for Tx
    interface link testing. Not yet implemented."
    ::= { radMM200TxInterfaceNVStatusEntry 12 }

radMM200TxInterfaceMajorAlarmMask OBJECT-TYPE
    SYNTAX AlarmByteType
    MAX-ACCESS    read-write
    STATUS current
    DESCRIPTION
    "Major Alarm mask:
    Bit 0 = Interface test
    Bit 1-7 = Spares
    0 = Mask, 1 = Allow"
    ::= { radMM200TxInterfaceNVStatusEntry 13 }

radMM200TxInterfaceMinorAlarmMask OBJECT-TYPE
    SYNTAX AlarmByteType
    MAX-ACCESS    read-write
    STATUS current
    DESCRIPTION
    "Minor Alarm mask:
    Bit 0 = Interface FIFO full
    Bit 1 = Interface FIFO empty
    Bit 2 = Interface PLL lock
    Bit 3 = Interface data activity detect
    Bit 4 = Interface clock activity detect
    Bit 5 = Interface Tx input framing valid, added for AASI
    Bit 6 = Interface signal loss, valid for some interfaces
    Bit 7 = Spares
    0 = Mask, 1 = Allow"
    ::= { radMM200TxInterfaceNVStatusEntry 14 }

radMM200TxInterfaceJitterControl OBJECT-TYPE
    SYNTAX INTEGER {
        normal(1),
        stamp2(2),
        stamp3(3)
    }
    MAX-ACCESS    read-write
    STATUS current
    DESCRIPTION
    "Selects the jitter control"
    ::= { radMM200TxInterfaceNVStatusEntry 15 }

-----
-- MM200 modulator interface volatile status information.
-----

radMM200TxInterfaceStatusTable OBJECT-TYPE
    SYNTAX SEQUENCE OF RadMM200TxInterfaceStatusEntry
    MAX-ACCESS    not-accessible
    STATUS mandatory
    DESCRIPTION
    "MM200 Tx interface volatile status Table"
    ::= { mm200MIBObjects 6 }

```

```

radMM200TxInterfaceStatusEntry OBJECT-TYPE
    SYNTAX RadMM200TxInterfaceStatusEntry
    MAX-ACCESS not-accessible
    STATUS current
    DESCRIPTION
        "MM200 Tx interface volatile status structure"
    INDEX { radMM200TxInterfaceIndex }
    ::= { radMM200TxInterfaceStatusTable 1 }

RadMM200TxInterfaceStatusEntry ::=
    SEQUENCE {
        radMM200TxInterfaceIndex INTEGER,
        radMM200TxInterfaceMajorAlarmStatus INTEGER,
        radMM200TxInterfaceMinorAlarmStatus INTEGER,
        radMM200TxInterfaceLatchedMajorAlarmStatus INTEGER,
        radMM200TxInterfaceLatchedMinorAlarmStatus INTEGER,
        radMM200TxInterfaceCard INTEGER
    }

radMM200TxInterfaceIndex OBJECT-TYPE
    SYNTAX INTEGER (1..4)
    MAX-ACCESS read-only
    STATUS current
    DESCRIPTION
        "Index into the MM200 Tx interface volatile table."
    ::= { radMM200TxInterfaceStatusEntry 1 }

radMM200TxInterfaceMajorAlarmStatus OBJECT-TYPE
    SYNTAX AlarmByteType
    MAX-ACCESS read-only
    STATUS current
    DESCRIPTION
        "Major Alarm status:
        Bit 0 = Interface test
        Bit 1-7 = Spares
        0 = Pass, 1 = Fail"
    ::= { radMM200TxInterfaceStatusEntry 2 }

radMM200TxInterfaceMinorAlarmStatus OBJECT-TYPE
    SYNTAX AlarmByteType
    MAX-ACCESS read-only
    STATUS current
    DESCRIPTION
        "Minor Alarm status:
        Bit 0 = Interface FIFO full
        Bit 1 = Interface FIFO empty
        Bit 2 = Interface PLL lock
        Bit 3 = Interface data activity detect
        Bit 4 = Interface clock activity detect
        Bit 5 = Interface Tx input framing valid, added for AASI
        Bit 6 = Interface signal loss, valid for some interfaces
        Bit 7 = Spares
        0 = Pass, 1 = Fail"
    ::= { radMM200TxInterfaceStatusEntry 3 }

radMM200TxInterfaceLatchedMajorAlarmStatus OBJECT-TYPE
    SYNTAX AlarmByteType
    MAX-ACCESS read-only
    STATUS current
    DESCRIPTION
        "Major Alarm status:
        Bit 0 = Interface test
        Bit 1-7 = Spares
        0 = Pass, 1 = Fail"
    ::= { radMM200TxInterfaceStatusEntry 4 }

```

```

radMM200TxInterfaceLatchedMinorAlarmStatus OBJECT-TYPE
    SYNTAX AlarmByteType
    MAX-ACCESS read-only
    STATUS current
    DESCRIPTION
    "Minor Alarm status:
    Bit 0 = Interface FIFO full
    Bit 1 = Interface FIFO empty
    Bit 2 = Interface PLL lock
    Bit 3 = Interface data activity detect
    Bit 4 = Interface clock activity detect
    Bit 5 = Interface Tx input framing valid, added for AASI
    Bit 6 = Interface signal loss, valid for some interfaces
    Bit 7 = Spares
    0 = Pass, 1 = Fail"
    ::= { radMM200TxInterfaceStatusEntry 5 }

radMM200TxInterfaceCard OBJECT-TYPE
    SYNTAX INTEGER {
        none(1),
        asi_aasi(2),
        nasi(3),
        t3e3(4),
        t1e1(5),
        ds0(6),
        parallel(7),
        oc3(8),
        hssi(9),
        smpte(10)
    }
    MAX-ACCESS read-only
    STATUS current
    DESCRIPTION
        "Interface card type."
    ::= { radMM200TxInterfaceStatusEntry 6 }

```

 -- MM200 demodulator non-volatile status information.

```

radMM200RxIFFrequency OBJECT-TYPE
    SYNTAX INTEGER (50000000..90000000)
    MAX-ACCESS read-write
    STATUS current
    DESCRIPTION
    "Selects IF frequency in Hz. This is the center
    frequency of the aggregate; the edge frequency,
    however, is dependent on the number of channels,
    symbol rate, and spacing. The frequency range
    of the MM200 is 50MHz to 90MHz."
    ::= { radMM200DemodNVStatus 1 }

radMM200RxIFUser1Frequency OBJECT-TYPE
    SYNTAX INTEGER (50000000..90000000)
    MAX-ACCESS read-write
    STATUS current
    DESCRIPTION
    "Selects IF user 1 frequency in Hz."
    ::= { radMM200DemodNVStatus 2 }

radMM200RxIFUser2Frequency OBJECT-TYPE
    SYNTAX INTEGER (50000000..90000000)
    MAX-ACCESS read-write
    STATUS current
    DESCRIPTION
    "Selects IF user 2 frequency in Hz."
    ::= { radMM200DemodNVStatus 3 }

```

```

radMM200RxIFUser3Frequency OBJECT-TYPE
    SYNTAX INTEGER (50000000..90000000)
    MAX-ACCESS read-write
    STATUS current
    DESCRIPTION
        "Selects IF user 3 frequency in Hz."
        ::= { radMM200DemodNVStatus 4 }

radMM200RxIFUser4Frequency OBJECT-TYPE
    SYNTAX INTEGER (50000000..90000000)
    MAX-ACCESS read-write
    STATUS current
    DESCRIPTION
        "Selects IF user 4 frequency in Hz."
        ::= { radMM200DemodNVStatus 5 }

radMM200RxIFSeperation OBJECT-TYPE
    SYNTAX INTEGER (100..150)
    MAX-ACCESS read-write
    STATUS current
    DESCRIPTION
        "Selects IF frequency separation in percent. It is
        the additional bandwidth percentage the carrier
        will cover over the original symbol rate. The range
        is 100% to 150%."
        ::= { radMM200DemodNVStatus 6 }

radMM200RxDataRate OBJECT-TYPE
    SYNTAX INTEGER (7000000..200000000)
    MAX-ACCESS read-write
    STATUS current
    DESCRIPTION
        "Selects the data rate in BPS. The data rate is
        variable from 7 Mbps to 200 Mbps."
        ::= { radMM200DemodNVStatus 7 }

radMM200RxSymbolRate OBJECT-TYPE
    SYNTAX INTEGER (3500000..28000000)
    MAX-ACCESS read-write
    STATUS current
    DESCRIPTION
        "Selects the data rate in BPS. The data rate is
        variable from 3.5Mbps to 28Mbps."
        ::= { radMM200DemodNVStatus 8 }

radMM200RxDemodulation OBJECT-TYPE
    SYNTAX INTEGER {
        qam4(1),
        qam16(2),
        qam32(3),
        qam64(4),
        qam128(5),
        qam256(6)
    }
    MAX-ACCESS read-write
    STATUS current
    DESCRIPTION
        "Selects the QAM demodulation type."
        ::= { radMM200DemodNVStatus 9 }

radMM200RxSpectrum OBJECT-TYPE
    SYNTAX InversionType
    MAX-ACCESS read-write
    STATUS current
    DESCRIPTION
        "Inverts the direction of rotation for the demodulation."

```

```

 ::= { radMM200DemodNVStatus 10 }

radMM200RxChannelSetting OBJECT-TYPE
    SYNTAX INTEGER {
        auto(1),
        oneChannel(2),
        twoChannel(3),
        threeChannel(4),
        fourChannel(5)
    }
    MAX-ACCESS read-write
    STATUS current
    DESCRIPTION
    "Selects the total number of channels in the MM200.
    Automatic selection allows the MM200 to use the
    maximum number of channels."
    ::= { radMM200DemodNVStatus 11 }

radMM200RxMajorAlarm1Mask OBJECT-TYPE
    SYNTAX AlarmByteType
    MAX-ACCESS read-write
    STATUS current
    DESCRIPTION
    "Major Alarm 1 mask:
    Bit 0 = Glue logic FPGA status
    Bit 1 = Data FPGA status
    Bit 2 = Signal lock detect
    Bit 3 = Sync lock detect
    Bit 4 = Data PLL lock detect
    Bit 5-7 = Spares
    0 = Mask, 1 = Allow"
    ::= { radMM200DemodNVStatus 12 }

radMM200RxMajorAlarm2Mask OBJECT-TYPE
    SYNTAX AlarmByteType
    MAX-ACCESS read-write
    STATUS current
    DESCRIPTION
    "Major Alarm 2 mask:
    Bit 0-7 = Spares
    0 = Mask, 1 = Allow"
    ::= { radMM200DemodNVStatus 13 }

radMM200RxMinorAlarm1Mask OBJECT-TYPE
    SYNTAX AlarmByteType
    MAX-ACCESS read-write
    STATUS current
    DESCRIPTION
    "Minor Alarm 1 mask:
    Bit 0 = Spare
    Bit 1 = Spare
    Bit 2 = Spare
    Bit 3 = Spare
    Bit 4 = Spare
    Bit 5 = Spare
    Bit 6 = Spare
    Bit 7 = Spare
    0 = Mask, 1 = Allow"
    ::= { radMM200DemodNVStatus 14 }

radMM200RxMinorAlarm2Mask OBJECT-TYPE
    SYNTAX AlarmByteType
    MAX-ACCESS read-write
    STATUS current
    DESCRIPTION
    "Minor Alarm 2 mask:
    Bit 0..7 = Spares

```

0 = Mask, 1 = Allow"
 ::= { radMM200DemodNVStatus 15 }

radMM200RxAcquisitionControl OBJECT-TYPE
 SYNTAX INTEGER {
 off(1),
 acquire(2)
 }
 MAX-ACCESS read-write
 STATUS current
 DESCRIPTION
 "Enables acquisition and tracking."
 ::= { radMM200DemodNVStatus 16 }

radMM200RxAcquisitionBandwidth OBJECT-TYPE
 SYNTAX INTEGER (50..400)
 MAX-ACCESS read-write
 STATUS current
 DESCRIPTION
 "Sets the +/- acquisition range in KHz, 1 KHz steps."
 ::= { radMM200DemodNVStatus 17 }

radMM200RxAcquisitionDelay OBJECT-TYPE
 SYNTAX INTEGER (10..255)
 MAX-ACCESS read-write
 STATUS current
 DESCRIPTION
 "Sets the time the demodulator remains at frequency before
 trying the next step. Delay is in secs."
 ::= { radMM200DemodNVStatus 18 }

radMM200RxReacquisitionDelay OBJECT-TYPE
 SYNTAX INTEGER (10..255)
 MAX-ACCESS read-write
 STATUS current
 DESCRIPTION
 "Sets the time the demodulator remains at frequency after
 it first loses lock. Delay is in secs."
 ::= { radMM200DemodNVStatus 19 }

radMM200AcquisitionStep OBJECT-TYPE
 SYNTAX INTEGER (10..100)
 MAX-ACCESS read-write
 STATUS current
 DESCRIPTION
 "Sets the frequency step size the demodulator will take when
 trying to acquire. Steps are in KHz."
 ::= { radMM200DemodNVStatus 20 }

radMM200TrackingStep OBJECT-TYPE
 SYNTAX INTEGER (10..100)
 MAX-ACCESS read-write
 STATUS current
 DESCRIPTION
 "Sets the step size the demodulator will use to remove the frequency
 error of a locked signal. Normally set to 10Hz. Steps are in Hz."
 ::= { radMM200DemodNVStatus 21 }

 -- MM200 demodulator status information.

radMM200RxMajorAlarm1Status OBJECT-TYPE
 SYNTAX AlarmByteType
 MAX-ACCESS read-only
 STATUS current
 DESCRIPTION

```

        "Major Alarm 1 status. The agent initializes this to
        the value '00000000'B
        Bit 0 = Glue logic FPGA status
        Bit 1 = Data FPGA status
        Bit 2 = Signal lock detect
        Bit 3 = Sync lock detect
        Bit 4 = Data PLL lock detect
        Bit 5-7 = Spares
        0 = Pass, 1 = Fail"
 ::= { radMM200DemodStatus 1 }

radMM200RxMajorAlarm2Status OBJECT-TYPE
    SYNTAX AlarmByteType
    MAX-ACCESS read-only
    STATUS current
    DESCRIPTION
        "Major Alarm 2 status. The agent initializes this to
        the value '00000000'B
        Bit 0-7 = Spares
        0 = Pass, 1 = Fail"
 ::= { radMM200DemodStatus 2 }

radMM200RxMinorAlarm1Status OBJECT-TYPE
    SYNTAX AlarmByteType
    MAX-ACCESS read-only
    STATUS current
    DESCRIPTION
        "Minor Alarm 1 status. The agent initializes this to
        the value '00000000'B
        Bit 0 = Spare
        Bit 1 = Spare
        Bit 2 = Spare
        Bit 3 = Spare
        Bit 4 = Spare
        Bit 5 = Spare
        Bit 6 = Spare
        Bit 7 = Spare
        0 = Pass, 1 = Fail"
 ::= { radMM200DemodStatus 3 }

radMM200RxMinorAlarm2Status OBJECT-TYPE
    SYNTAX AlarmByteType
    MAX-ACCESS read-only
    STATUS current
    DESCRIPTION
        "Minor Alarm 2 status. The agent initializes this to
        the value '00000000'B
        Bit 0..7 = Spares
        0 = Pass, 1 = Fail"
 ::= { radMM200DemodStatus 4 }

radMM200RxlatchedMajorAlarm1Status OBJECT-TYPE
    SYNTAX AlarmByteType
    MAX-ACCESS read-only
    STATUS current
    DESCRIPTION
        "A bit field. On startup, the agent initializes this to
        the value '00000000'B.
        Bit 0 = Glue logic FPGA status
        Bit 1 = Data FPGA status
        Bit 2 = Signal lock detect
        Bit 3 = Sync lock detect
        Bit 4 = Data PLL lock detect
        Bit 5-7 = Spares
        0 = Pass, 1 = Fail"
 ::= { radMM200DemodStatus 5 }

```

```

radMM200RxLatchedMajorAlarm2Status OBJECT-TYPE
    SYNTAX AlarmByteType
    MAX-ACCESS read-only
    STATUS current
    DESCRIPTION
        "A bit field. On startup, the agent initializes this to
        the value '00000000'B.
        Bit 0..7 = Spares
        0 = Pass, 1 = Fail"
    ::= { radMM200DemodStatus 6 }

radMM200RxLatchedMinorAlarm1Status OBJECT-TYPE
    SYNTAX AlarmByteType
    MAX-ACCESS read-only
    STATUS current
    DESCRIPTION
        "A bit field. On startup, the agent initializes this to
        the value '00000000'B.
        Bit 0 = Spare
        Bit 1 = Spare
        Bit 2 = Spare
        Bit 3 = Spare
        Bit 4 = Spare
        Bit 5 = Spare
        Bit 6 = Spare
        Bit 7 = Spare
        0 = Pass, 1 = Fail"
    ::= { radMM200DemodStatus 7 }

radMM200RxLatchedMinorAlarm2Status OBJECT-TYPE
    SYNTAX AlarmByteType
    MAX-ACCESS read-only
    STATUS current
    DESCRIPTION
        "A bit field. On startup, the agent initializes this to
        the value '00000000'B.
        Bit 0..7 = Spares
        0 = Pass, 1 = Fail"
    ::= { radMM200DemodStatus 8 }

radMM200RxMaxPayload OBJECT-TYPE
    SYNTAX INTEGER (0..200000000)
    MAX-ACCESS read-only
    STATUS current
    DESCRIPTION
        "Maximum payload at current demodulation."
    ::= { radMM200DemodStatus 9 }

radMM200RxPercentUtilization OBJECT-TYPE
    SYNTAX INTEGER (0..65536)
    MAX-ACCESS read-only
    STATUS current
    DESCRIPTION
        "% utilization, implied decimal point.
        (i.e. 7985 means 79.85%"
    ::= { radMM200DemodStatus 10 }

radMM200RxBandwidth OBJECT-TYPE
    SYNTAX INTEGER (0..40000000)
    MAX-ACCESS read-only
    STATUS current
    DESCRIPTION
        "Current bandwidth usage."
    ::= { radMM200DemodStatus 11 }

radMM200RxInputLevel OBJECT-TYPE
    SYNTAX INTEGER (-1000..100)

```



```

MAX-ACCESS    read-only
STATUS        current
DESCRIPTION
    "Aggregate input level in dBm. Signed implied
    decimal point.
    (i.e. -265 mean -26.5dBm)"
 ::= { radMM200DemodStatus 12 }

```

 -- MM200 demodulator channel non-volatile status information.

```

radMM200RxChannelNVStatusTable OBJECT-TYPE
SYNTAX SEQUENCE OF RadMM200RxChannelNVStatusEntry
MAX-ACCESS    not-accessible
STATUS        mandatory
DESCRIPTION
    "MM200 Rx channel non-volatile status Table"
 ::= { mm200MIBObjects 9 }

```

```

radMM200RxChannelNVStatusEntry OBJECT-TYPE
SYNTAX RadMM200RxChannelNVStatusEntry
MAX-ACCESS    not-accessible
STATUS        current
DESCRIPTION
    "MM200 Rx channel non-volatile status structure"
INDEX         { radMM200RxChannelNVIndex }
 ::= { radMM200RxChannelNVStatusTable 1 }

```

```

RadMM200RxChannelNVStatusEntry ::=
SEQUENCE     {
    radMM200RxChannelNVIndex INTEGER,
    radMM200RxChannelMajorAlarmMask INTEGER,
    radMM200RxChannelMinorAlarmMask INTEGER
}

```

```

radMM200RxChannelNVIndex OBJECT-TYPE
SYNTAX INTEGER (1..4)
MAX-ACCESS    read-only
STATUS        current
DESCRIPTION
    "Index into the MM200 Rx channel non-volatile table."
 ::= { radMM200RxChannelNVStatusEntry 1 }

```

```

radMM200RxChannelMajorAlarmMask OBJECT-TYPE
SYNTAX AlarmByteType
MAX-ACCESS    read-write
STATUS        current
DESCRIPTION
    "Major Alarm mask:
    Bit 0 = Demod daughter board FPGA status
    Bit 1 = RF PLL lock detect status
    Bit 2-7 = Spares
    0 = Mask, 1 = Allow"
 ::= { radMM200RxChannelNVStatusEntry 2 }

```

```

radMM200RxChannelMinorAlarmMask OBJECT-TYPE
SYNTAX AlarmByteType
MAX-ACCESS    read-write
STATUS        current
DESCRIPTION
    "Minor Alarm mask:
    Bit 0 = QAM lock status
    Bit 1 = FEC lock status
    Bit 2 = FIFO full status
    Bit 3 = FIFO empty status
    Bit 4 = Sync lock status

```

```

        Bit 5 = FIFO reload
        Bit 6 = FIFO active
        Bit 7 = Track fault
        0 = Mask, 1 = Allow"
 ::= { radMM200RxChannelINVStatusEntry 3 }

-----
-- MM200 demodulator channel status information.

radMM200RxChannelStatusTable OBJECT-TYPE
    SYNTAX SEQUENCE OF RadMM200RxChannelStatusEntry
    MAX-ACCESS not-accessible
    STATUS mandatory
    DESCRIPTION
        "MM200 Rx channel volatile status Table"
 ::= { mm200MIBObjects 10 }

radMM200RxChannelStatusEntry OBJECT-TYPE
    SYNTAX RadMM200RxChannelStatusEntry
    MAX-ACCESS not-accessible
    STATUS current
    DESCRIPTION
        "MM200 Rx channel volatile status structure"
    INDEX { radMM200RxChannelIndex }
 ::= { radMM200RxChannelStatusTable 1 }

RadMM200RxChannelStatusEntry ::=
    SEQUENCE {
        radMM200RxChannelIndex INTEGER,
        radMM200RxChannelMajorAlarmStatus INTEGER,
        radMM200RxChannelMinorAlarmStatus INTEGER,
        radMM200RxChannelLatchedMajorAlarmStatus INTEGER,
        radMM200RxChannelLatchedMinorAlarmStatus INTEGER,
        radMM200RxChannelBaudRate INTEGER,
        radMM200RxChannelOffsetFrequency INTEGER,
        radMM200RxChannelAGCIntegrator INTEGER,
        radMM200RxChannelSNR INTEGER,
        radMM200RxChannelCBA INTEGER,
        radMM200RxChannelUBA INTEGER,
        radMM200RxChannelInputLevel INTEGER
    }

radMM200RxChannelIndex OBJECT-TYPE
    SYNTAX INTEGER (1..4)
    MAX-ACCESS read-only
    STATUS current
    DESCRIPTION
        "Index into the MM200 Rx channel volatile table."
 ::= { radMM200RxChannelStatusEntry 1 }

radMM200RxChannelMajorAlarmStatus OBJECT-TYPE
    SYNTAX AlarmByteType
    MAX-ACCESS read-only
    STATUS current
    DESCRIPTION
        "Major Alarm status:
        Bit 0 = Demod daughter board FPGA status
        Bit 1 = RF PLL lock detect status
        Bit 2-7 = Spares
        0 = PASS, 1 = FAIL"
 ::= { radMM200RxChannelStatusEntry 2 }

radMM200RxChannelMinorAlarmStatus OBJECT-TYPE
    SYNTAX AlarmByteType
    MAX-ACCESS read-only
    STATUS current

```

```

DESCRIPTION
    "Minor Alarm status:
    Bit 0 = QAM lock status
    Bit 1 = FEC lock status
    Bit 2 = FIFO full status
    Bit 3 = FIFO empty status
    Bit 4 = Sync lock status
    Bit 5 = FIFO reload
    Bit 6 = FIFO active
    Bit 7 = Track fault
    0 = PASS, 1 = FAIL"
 ::= { radMM200RxChannelStatusEntry 3 }

radMM200RxChannelLatchedMajorAlarmStatus OBJECT-TYPE
SYNTAX AlarmByteType
MAX-ACCESS read-only
STATUS current
DESCRIPTION
    "Major Alarm status:
    Bit 0 = Mod daughter board FPGA status
    Bit 1 = RF PLL lock detect status
    Bit 2-7 = Spares
    0 = PASS, 1 = FAIL"
 ::= { radMM200RxChannelStatusEntry 4 }

radMM200RxChannelLatchedMinorAlarmStatus OBJECT-TYPE
SYNTAX AlarmByteType
MAX-ACCESS read-only
STATUS current
DESCRIPTION
    "Minor Alarm status:
    Bit 0 = QAM lock status
    Bit 1 = FEC lock status
    Bit 2 = FIFO full status
    Bit 3 = FIFO empty status
    Bit 4 = Sync lock status
    Bit 5 = FIFO reload
    Bit 6 = FIFO active
    Bit 7 = Spare
    0 = PASS, 1 = FAIL"
 ::= { radMM200RxChannelStatusEntry 5 }

radMM200RxChannelBaudRate OBJECT-TYPE
SYNTAX INTEGER (7000000..200000000)
MAX-ACCESS read-only
STATUS current
DESCRIPTION
    "Channel baud rate"
 ::= { radMM200RxChannelStatusEntry 6 }

radMM200RxChannelOffsetFrequency OBJECT-TYPE
SYNTAX INTEGER (-50000..50000)
MAX-ACCESS read-only
STATUS current
DESCRIPTION
    "Channel offset frequency in Hz"
 ::= { radMM200RxChannelStatusEntry 7 }

radMM200RxChannelAGCIntegrator OBJECT-TYPE
SYNTAX INTEGER (0..10000)
MAX-ACCESS read-only
STATUS current
DESCRIPTION
    "Channel AGC integrator"
 ::= { radMM200RxChannelStatusEntry 8 }

```

```

radMM200RxChannelSNR OBJECT-TYPE
    SYNTAX INTEGER (0..100)
    MAX-ACCESS read-only
    STATUS current
    DESCRIPTION
        "Channel SNR, signal to noise ratio."
    ::= { radMM200RxChannelStatusEntry 9 }

radMM200RxChannelCBA OBJECT-TYPE
    SYNTAX INTEGER (0..65536)
    MAX-ACCESS read-only
    STATUS current
    DESCRIPTION
        "Channel CBA, correctable block accumulator."
    ::= { radMM200RxChannelStatusEntry 10 }

radMM200RxChannelUBA OBJECT-TYPE
    SYNTAX INTEGER (0..65536)
    MAX-ACCESS read-only
    STATUS current
    DESCRIPTION
        "Channel UBA, uncorrectable block accumulator."
    ::= { radMM200RxChannelStatusEntry 11 }

radMM200RxChannelInputLevel OBJECT-TYPE
    SYNTAX INTEGER (-1000..100)
    MAX-ACCESS read-only
    STATUS current
    DESCRIPTION
        "Channel input level in dBm. Signed implied decimal point
        -265 means -26.5 dBm"
    ::= { radMM200RxChannelStatusEntry 12 }

```

 -- MM200 demodulator interface non-volatile status information.

```

radMM200RxInterfaceNVStatusTable OBJECT-TYPE
    SYNTAX SEQUENCE OF RadMM200RxInterfaceNVStatusEntry
    MAX-ACCESS not-accessible
    STATUS mandatory
    DESCRIPTION
        "MM200 Rx interface non-volatile status Table"
    ::= { mm200MIBObjects 11 }

radMM200RxInterfaceNVStatusEntry OBJECT-TYPE
    SYNTAX RadMM200RxInterfaceNVStatusEntry
    MAX-ACCESS not-accessible
    STATUS current
    DESCRIPTION
        "MM200 Rx interface non-volatile status structure"
    INDEX { radMM200RxInterfaceNVIndex }
    ::= { radMM200RxInterfaceNVStatusTable 1 }

RadMM200RxInterfaceNVStatusEntry ::=
    SEQUENCE {
        radMM200RxInterfaceNVIndex INTEGER,
        radMM200RxInterfacePID INTEGER,
        radMM200RxInterfaceDataRate INTEGER,
        radMM200RxInterfaceControl INTEGER,
        radMM200RxInterfaceType INTEGER,
        radMM200RxInterfaceSubType INTEGER,
        radMM200RxInterfaceClockSource INTEGER,
        radMM200RxInterfaceClockFrequency INTEGER,
        radMM200RxInterfaceFraming INTEGER,
        radMM200RxInterfaceVolume INTEGER,
        radMM200RxInterfaceClockPolarity INTEGER,

```

```

        radMM200RxInterfaceDataInvert INTEGER,
        radMM200RxInterfaceTerrestrialLoopback INTEGER,
        radMM200RxInterfacePRBS INTEGER,
        radMM200RxInterfaceMajorAlarmMask INTEGER,
        radMM200RxInterfaceMinorAlarmMask INTEGER,
        radMM200RxInterfaceJitterControl INTEGER,
        radMM200RxInterfaceByteGapping INTEGER
    }

radMM200RxInterfaceNVIndex OBJECT-TYPE
    SYNTAX INTEGER (1..4)
    MAX-ACCESS read-only
    STATUS current
    DESCRIPTION
        "Index into the MM200 Rx interface on-volatile table."
    ::= { radMM200RxInterfaceNVStatusEntry 1 }

radMM200RxInterfacePID OBJECT-TYPE
    SYNTAX INTEGER (0..8192)
    MAX-ACCESS read-write
    STATUS current
    DESCRIPTION
        "Selects the interface Program Id. If not in 188
        byte framing mode (unframed), this PID steers the
        packet to the appropriate interface. In the MM200,
        only one framed interface is allowed and its packets
        are sent in the clear, without modifications. The
        Null PID and the PIDs of the unframed interfaces should
        be unique. All packets PIDs not equal to these will
        be sent to the framed interface."
    ::= { radMM200RxInterfaceNVStatusEntry 2 }

radMM200RxInterfaceDataRate OBJECT-TYPE
    SYNTAX INTEGER (64000..200000000)
    MAX-ACCESS read-write
    STATUS current
    DESCRIPTION
        "Selects the data rate in BPS of the individual
        interfaces. The data rate is T3, E3, or STS1
        for G.703
        155.52M BPS for OC3 and STM1
        1.544M BPS for T1
        2.048M BPS for E1
        Variable for parallel and ASI
        64K BPS for 8 channel DS0
        The range is between 64K to 200M BPS"
    ::= { radMM200RxInterfaceNVStatusEntry 3 }

radMM200RxInterfaceControl OBJECT-TYPE
    SYNTAX ControlType
    MAX-ACCESS read-write
    STATUS current
    DESCRIPTION
        "Controls the Rx interface enabling."
    ::= { radMM200RxInterfaceNVStatusEntry 4 }

radMM200RxInterfaceType OBJECT-TYPE
    SYNTAX INTEGER {
        asi(1)
        aasi(2)
        t3(3),
        e3(4),
        sts1(5),
        t1(6),
        e1(7),
        ds0x8(8),
        ds0x7A(9),
    }

```

```

        parallelDVB(10),
        parallelM2P(11),
        oc3(12),
        stm1(13),
        hssi(14),
        smpt19(15)
        smpt38(16)
    }
MAX-ACCESS      read-write
STATUS          current
DESCRIPTION     "Selects the Rx interface type."
 ::= { radMM200RxInterfaceNVStatusEntry 5 }

radMM200RxInterfaceSubType OBJECT-TYPE
SYNTAX          INTEGER {
                    spare(1),
                    }
MAX-ACCESS      read-write
STATUS          current
DESCRIPTION     "Selects the Rx interface sub-type."
 ::= { radMM200RxInterfaceNVStatusEntry 6 }

radMM200RxInterfaceClockSource OBJECT-TYPE
SYNTAX          INTEGER {
                    rxclk(1),
                    extbnc(2),
                    extbal(3),
                    internalclk(4)
                    }
MAX-ACCESS      read-write
STATUS          current
DESCRIPTION     "Selects the Rx interface clock source."
 ::= { radMM200RxInterfaceNVStatusEntry 7 }

radMM200RxInterfaceClockFrequency OBJECT-TYPE
SYNTAX          INTEGER {
                    mhz2048(1),
                    mhz5(2),
                    mhz10(3),
                    datarate(4)
                    }
MAX-ACCESS      read-write
STATUS          current
DESCRIPTION     "Selects the Rx interface clock frequency."
 ::= { radMM200RxInterfaceNVStatusEntry 8 }

radMM200RxInterfaceFraming OBJECT-TYPE
SYNTAX          INTEGER {
                    unframed(1),
                    mpeg188(2),
                    mpeg204(3),
                    null188(4),
                    null204(5)
                    }
MAX-ACCESS      read-write
STATUS          current
DESCRIPTION     "Selects Unframed (184 Byte proprietary packet),
                    MPEG Sync Byte and MPEG Sync Byte plus ReedSolomon."
 ::= { radMM200RxInterfaceNVStatusEntry 9 }

radMM200RxInterfaceVolume OBJECT-TYPE
SYNTAX          INTEGER (0..255)

```

```

MAX-ACCESS    read-write
STATUS        current
DESCRIPTION
    "Sets the volume on the audio channel on the DS0
    interfaces"
::= { radMM200RxInterfaceNVStatusEntry 10 }

radMM200RxInterfaceClockPolarity OBJECT-TYPE
SYNTAX INTEGER {
    normal(1),
    inverted(2),
}
MAX-ACCESS    read-write
STATUS        current
DESCRIPTION
    "Selects clock polarity for Tx terrestrial clock
    relative to Tx data."
::= { radMM200RxInterfaceNVStatusEntry 11 }

radMM200RxInterfaceDataInvert OBJECT-TYPE
SYNTAX InversionType
MAX-ACCESS    read-write
STATUS        current
DESCRIPTION
    "Selects data polarity"
::= { radMM200RxInterfaceNVStatusEntry 12 }

radMM200RxInterfaceTerrestrialLoopback OBJECT-TYPE
SYNTAX ControlType
MAX-ACCESS    read-write
STATUS        current
DESCRIPTION
    "Enables or disables Rx Interface Terrestrial Loopback."
::= { radMM200RxInterfaceNVStatusEntry 13 }

radMM200RxInterfacePRBS OBJECT-TYPE
SYNTAX INTEGER {
    normal(1),
    prbs23(2),
    prbs23m(3),
    prbs15(4),
    prbs15m(5)
}
MAX-ACCESS    read-write
STATUS        current
DESCRIPTION
    "Selects the pseudo-random bit sequence for Rx
    interface link testing."
::= { radMM200RxInterfaceNVStatusEntry 14 }

radMM200RxInterfaceMajorAlarmMask OBJECT-TYPE
SYNTAX AlarmByteType
MAX-ACCESS    read-write
STATUS        current
DESCRIPTION
    "Major Alarm mask:
    Bit 0 = Interface test
    Bit 1-7 = Spares
    0 = Mask, 1 = Allow"
::= { radMM200RxInterfaceNVStatusEntry 15 }

radMM200RxInterfaceMinorAlarmMask OBJECT-TYPE
SYNTAX AlarmByteType
MAX-ACCESS    read-write
STATUS        current
DESCRIPTION
    "Minor Alarm mask:

```

```

    Bit 0 = Interface FIFO full
    Bit 1 = Interface FIFO empty
    Bit 2 = Interface PLL lock
    Bit 3 = Interface data activity detect
    Bit 4 = Interface clock activity detect
    Bit 5 = Interface Tx input framing valid, added for AASI
    Bit 6 = Interface signal loss, valid for some interfaces
    Bit 7 = Spare
    0 = Mask, 1 = Allow"
 ::= { radMM200RxInterfaceNVStatusEntry 16 }

radMM200RxInterfaceJitterControl OBJECT-TYPE
    SYNTAX INTEGER {
        inch(1),
        slow(2),
        medium(3),
        fast(4),
        stamp2(5),
        stamp3(6)
    }
    MAX-ACCESS read-write
    STATUS current
    DESCRIPTION
        "Selects the jitter control"
    ::= { radMM200RxInterfaceNVStatusEntry 17 }

radMM200RxInterfaceByteGapping OBJECT-TYPE
    SYNTAX INTEGER (0..255)
    MAX-ACCESS read-write
    STATUS current
    DESCRIPTION
        "Selects the jitter control"
    ::= { radMM200RxInterfaceNVStatusEntry 18 }

```

 -- MM200 demodulator interface volatile status information.

```

radMM200RxInterfaceStatusTable OBJECT-TYPE
    SYNTAX SEQUENCE OF RadMM200RxInterfaceStatusEntry
    MAX-ACCESS not-accessible
    STATUS mandatory
    DESCRIPTION
        "MM200 Rx interface volatile status Table"
    ::= { mm200MIBObjects 12 }

```

```

radMM200RxInterfaceStatusEntry OBJECT-TYPE
    SYNTAX RadMM200RxInterfaceStatusEntry
    MAX-ACCESS not-accessible
    STATUS current
    DESCRIPTION
        "MM200 Rx interface volatile status structure"
    INDEX { radMM200RxInterfaceIndex }
    ::= { radMM200RxInterfaceStatusTable 1 }

```

```

RadMM200RxInterfaceStatusEntry ::=
    SEQUENCE {
        radMM200RxInterfaceIndex INTEGER,
        radMM200RxInterfaceMajorAlarmStatus INTEGER,
        radMM200RxInterfaceMinorAlarmStatus INTEGER,
        radMM200RxInterfaceLatchedMajorAlarmStatus INTEGER,
        radMM200RxInterfaceLatchedMinorAlarmStatus INTEGER,
        radMM200RxInterfaceCard INTEGER
    }

```

```

radMM200RxInterfaceIndex OBJECT-TYPE
    SYNTAX INTEGER (1..4)

```



```

MAX-ACCESS    read-only
STATUS        current
DESCRIPTION
    "Index into the MM200 Rx interface volatile table."
 ::= { radMM200RxInterfaceStatusEntry 1 }

radMM200RxInterfaceMajorAlarmStatus OBJECT-TYPE
SYNTAX        AlarmByteType
MAX-ACCESS    read-only
STATUS        current
DESCRIPTION
    "Major Alarm status:
     Bit 0 = Interface test
     Bit 1-7 = Spares
     0 = Pass, 1 = Fail"
 ::= { radMM200RxInterfaceStatusEntry 2 }

radMM200RxInterfaceMinorAlarmStatus OBJECT-TYPE
SYNTAX        AlarmByteType
MAX-ACCESS    read-only
STATUS        current
DESCRIPTION
    "Minor Alarm status:
     Bit 0 = Interface FIFO full
     Bit 1 = Interface FIFO empty
     Bit 2 = Interface PLL lock
     Bit 3 = Interface data activity detect
     Bit 4 = Interface clock activity detect
     Bit 5 = Interface Tx input framing valid, added for AASI
     Bit 6 = Interface signal loss, valid for some interfaces
     Bit 7 = Spare
     0 = Pass, 1 = Fail"
 ::= { radMM200RxInterfaceStatusEntry 3 }

radMM200RxInterfaceLatchedMajorAlarmStatus OBJECT-TYPE
SYNTAX        AlarmByteType
MAX-ACCESS    read-only
STATUS        current
DESCRIPTION
    "Major Alarm status:
     Bit 0 = Interface test
     Bit 1-7 = Spares
     0 = Pass, 1 = Fail"
 ::= { radMM200RxInterfaceStatusEntry 4 }

radMM200RxInterfaceLatchedMinorAlarmStatus OBJECT-TYPE
SYNTAX        AlarmByteType
MAX-ACCESS    read-only
STATUS        current
DESCRIPTION
    "Minor Alarm status:
     Bit 0 = Interface FIFO full
     Bit 1 = Interface FIFO empty
     Bit 2 = PLL lock
     Bit 3 = Interface data activity detect
     Bit 4 = Interface clock activity detect
     Bit 5 = Interface Tx input framing valid, added for AASI
     Bit 6 = Interface signal loss, valid for some interfaces
     Bit 7 = Spare
     0 = Pass, 1 = Fail"
 ::= { radMM200RxInterfaceStatusEntry 5 }

radMM200RxInterfaceCard OBJECT-TYPE
SYNTAX        INTEGER {
                    none(1),
                    asi_aasi(2),
                    nasi(3),

```

```

        t3e3(4),
        t1e1(5),
        ds0(6),
        parallel(7),
        oc3(8),
        hssi(9),
        smpte(10)
    }
    MAX-ACCESS    read-only
    STATUS current
    DESCRIPTION
        "Interface card type."
    ::= { radMM200RxInterfaceStatusEntry 6 }

```

 -- MM200 common non-volatile status information.

```

radMM200CommonControlMode OBJECT-TYPE
    SYNTAX INTEGER {
        local(1),
        terminal(2),
        computer(3),
        ethernet(4)
    }
    MAX-ACCESS    read-write
    STATUS current
    DESCRIPTION
        "Selects Tx control mode."
    ::= { radMM200CommonNVStatus 1 }

radMM200CommonLastRateControl OBJECT-TYPE
    SYNTAX INTEGER {
        symbol(1),
        data(2),
        auto(3)
    }
    MAX-ACCESS    read-write
    STATUS current
    DESCRIPTION
        "Selects the last rate control"
    ::= { radMM200CommonNVStatus 2 }

radMM200CommonUserMode OBJECT-TYPE
    SYNTAX INTEGER {
        debug(1),
        level0(2),
        level1(3),
        level2(4)
    }
    MAX-ACCESS    read-write
    STATUS current
    DESCRIPTION
        "Selects system user MAX-ACCESS levels"
    ::= { radMM200CommonNVStatus 3 }

radMM200CommonFrequencyPlan OBJECT-TYPE
    SYNTAX INTEGER {
        auto(1),
        user(2)
    }
    MAX-ACCESS    read-write
    STATUS current
    DESCRIPTION
        "Selects system frequency plan."
    ::= { radMM200CommonNVStatus 4 }

```

```

radMM200CommonAlarm1Mask OBJECT-TYPE
    SYNTAX AlarmByteType
    MAX-ACCESS read-write
    STATUS current
    DESCRIPTION
        "Common Alarm 1 mask:
        Bit 0 = Glue logic FPGA status
        Bit 1 = Test FPGA status
        Bit 2-7 = Spares
        0 = Mask, 1 = Allow"
    ::= { radMM200CommonNVStatus 5 }

radMM200CommonAlarm2Mask OBJECT-TYPE
    SYNTAX AlarmByteType
    MAX-ACCESS read-write
    STATUS current
    DESCRIPTION
        "Common Alarm 2 mask:
        Bit 0..7 = Spares
        0 = Mask, 1 = Allow"
    ::= { radMM200CommonNVStatus 6 }

radMM200CommonResetSNMP OBJECT-TYPE
    SYNTAX INTEGER (123456789)
    MAX-ACCESS read-write
    STATUS current
    DESCRIPTION
        "Forces the SNMP agent to re-initialize and restart."
    ::= { radMM200CommonNVStatus 7 }

radMM200CommonLatchedAlarmsClear OBJECT-TYPE
    SYNTAX INTEGER
    MAX-ACCESS read-write
    STATUS current
    DESCRIPTION
        "Any write to this object clears the latched alarms."
    ::= { radMM200CommonNVStatus 8 }

```

 -- MM200 common non-volatile status information.

```

radMM200CommonAlarm1Status OBJECT-TYPE
    SYNTAX AlarmByteType
    MAX-ACCESS read-only
    STATUS current
    DESCRIPTION
        "A bit field. On startup, the agent initializes this to
        the value '00000000'B
        Bit 0 = Glue logic FPGA status
        Bit 1 = Test FPGA status
        Bit 2-7 = Spares
        0 = Pass, 1 = Fail"
    ::= { radMM200CommonStatus 1 }

radMM200CommonAlarm2Status OBJECT-TYPE
    SYNTAX AlarmByteType
    MAX-ACCESS read-only
    STATUS current
    DESCRIPTION
        "A bit field. On startup, the agent initializes this to
        the value '00000000'B
        Bit 0..7 = Spares
        0 = Pass, 1 = Fail"
    ::= { radMM200CommonStatus 2 }

```

```

radMM200CommonLatchedAlarm1Status OBJECT-TYPE
    SYNTAX AlarmByteType
    MAX-ACCESS read-only
    STATUS current
    DESCRIPTION
        "A bit field. On startup, the agent initializes this to
        the value '00000000'B
        Bit 0 = Glue logic FPGA status
        Bit 1 = Test FPGA status
        Bit 2-7 = Spares
        0 = Pass, 1 = Fail"
    ::= { radMM200CommonStatus 3 }

radMM200CommonLatchedAlarm2Status OBJECT-TYPE
    SYNTAX AlarmByteType
    MAX-ACCESS read-only
    STATUS current
    DESCRIPTION
        "A bit field. On startup, the agent initializes this to
        the value '00000000'B
        Bit 0..7 = Spares
        0 = Pass, 1 = Fail"
    ::= { radMM200CommonStatus 4 }

-----
-----

-- MM200 Trap definitions.

-- Include Prefix for compatibility with SNMPv1 traps and procedures
-- employed by multi-lingual and proxy forwarding systems

radMM200MIBTrapPrefix OBJECT IDENTIFIER ::= { radMM200MIBTraps 0 }

radMM200ColdStartTrap NOTIFICATION-TYPE
    STATUS current
    DESCRIPTION
        "Unexpected restart."
    ::= { radMM200MIBTrapPrefix 1 }

radMM200AuthenticationFailureTrap NOTIFICATION-TYPE
    STATUS current
    DESCRIPTION
        "Received a message that has failed authentication."
    ::= { radMM200MIBTrapPrefix 2 }

radMM200ModMajorAlarmTrap NOTIFICATION-TYPE
    STATUS current
    DESCRIPTION
        "Modulator major alarm trap."
    ::= { radMM200MIBTrapPrefix 3 }

radMM200ModMinorAlarmTrap NOTIFICATION-TYPE
    STATUS current
    DESCRIPTION
        "Modulator minor alarm trap."
    ::= { radMM200MIBTrapPrefix 4 }

radMM200DemodMajorAlarmTrap NOTIFICATION-TYPE
    STATUS current
    DESCRIPTION
        "Demodulator major alarm trap."
    ::= { radMM200MIBTrapPrefix 5 }

radMM200DemodMinorAlarmTrap NOTIFICATION-TYPE

```

```

STATUS current
DESCRIPTION
    "Demodulator minor alarm trap."
::= { radMM200MIBTrapPrefix 6 }

radMM200CommonAlarmTrap NOTIFICATION-TYPE
STATUS current
DESCRIPTION "Common alarm trap."
::= { radMM200MIBTrapPrefix 7 }

-----
-- MM200 MIB conformance

mm200ModNVStatusGroup OBJECT-GROUP
OBJECTS {
    radMM200TxCarrierControl,
    radMM200TxTransmitPower,
    radMM200TxIFFrequency,
    radMM200TxIFUser1Frequency,
    radMM200TxIFUser2Frequency,
    radMM200TxIFUser3Frequency,
    radMM200TxIFUser4Frequency,
    radMM200TxIFSeperation,
    radMM200TxDataRate,
    radMM200TxSymbolRate,
    radMM200TxModulation,
    radMM200TxSpectrum,
    radMM200TxCarrierMode,
    radMM200TxChannelSetting,
    radMM200TxMajorAlarm1Mask,
    radMM200TxMajorAlarm2Mask,
    radMM200TxMinorAlarm1Mask,
    radMM200TxMinorAlarm2Mask,
    radMM200TxPRBS
}
STATUS current
DESCRIPTION "Modulator non-volatile status group."
::= { mm200Groups 1 }

mm200ModStatusGroup OBJECT-GROUP
OBJECTS {
    radMM200TxMajorAlarm1Status,
    radMM200TxMajorAlarm2Status,
    radMM200TxMinorAlarm1Status,
    radMM200TxMinorAlarm2Status,
    radMM200TxLatchedMajorAlarm1Status,
    radMM200TxLatchedMajorAlarm2Status,
    radMM200TxLatchedMinorAlarm1Status,
    radMM200TxLatchedMinorAlarm2Status,
    radMM200TxCarrierStatus,
    radMM200TxMaxPayload,
    radMM200TxPercentUtilization,
    radMM200TxBandwidth
}
STATUS current
DESCRIPTION "Modulator volatile status group."
::= { mm200Groups 2 }

mm200ModChannelNVStatusGroup OBJECT-GROUP
OBJECTS {
    radMM200TxChannelNVIndex,
    radMM200TxChannelMajorAlarmMask,
    radMM200TxChannelMinorAlarmMask
}
STATUS current
DESCRIPTION

```

```

"Modulator channel non-volatile status group."
 ::= { mm200Groups 3 }

mm200ModChannelStatusGroup OBJECT-GROUP
  OBJECTS
    {
      radMM200TxChannelIndex,
      radMM200TxChannelMajorAlarmStatus,
      radMM200TxChannelMinorAlarmStatus,
      radMM200TxChannelLatchedMajorAlarmStatus,
      radMM200TxChannelLatchedMinorAlarmStatus,
      radMM200TxChannelBaudRate,
      radMM200TxChannelBaudState
    }
  STATUS current
  DESCRIPTION "Modulator channel volatile status group."
  ::= { mm200Groups 4 }

mm200ModInterfaceNVStatusGroup OBJECT-GROUP
  OBJECTS
    {
      radMM200TxInterfaceNVIndex,
      radMM200TxInterfacePID,
      radMM200TxInterfaceDataRate,
      radMM200TxInterfaceControl,
      radMM200TxInterfaceType,
      radMM200TxInterfaceSubType,
      radMM200TxInterfaceFraming,
      radMM200TxInterfaceVolume,
      radMM200TxInterfaceClockPolarity,
      radMM200TxInterfaceDataInvert,
      radMM200TxInterfaceBasebandLoopback,
      radMM200TxInterfacePRBS,
      radMM200TxInterfaceMajorAlarmMask,
      radMM200TxInterfaceMinorAlarmMask,
      radMM200TxInterfaceJitterControl
    }
  STATUS current
  DESCRIPTION "Modulator interface non-volatile status group."
  ::= { mm200Groups 5 }

mm200ModInterfaceStatusGroup OBJECT-GROUP
  OBJECTS
    {
      radMM200TxInterfaceIndex,
      radMM200TxInterfaceMajorAlarmStatus,
      radMM200TxInterfaceMinorAlarmStatus,
      radMM200TxInterfaceLatchedMajorAlarmStatus,
      radMM200TxInterfaceLatchedMinorAlarmStatus
    }
  STATUS current
  DESCRIPTION "Modulator interface volatile status group."
  ::= { mm200Groups 6 }

mm200DemodNVStatusGroup OBJECT-GROUP
  OBJECTS
    {
      radMM200RxIFFrequency,
      radMM200RxIFUser1Frequency,
      radMM200RxIFUser2Frequency,
      radMM200RxIFUser3Frequency,
      radMM200RxIFUser4Frequency,
      radMM200RxIFSeperation,
      radMM200RxDataRate,
      radMM200RxSymbolRate,
      radMM200RxDemodulation,
      radMM200RxSpectrum,
      radMM200RxChannelSetting,
      radMM200RxMajorAlarm1Mask,
      radMM200RxMajorAlarm2Mask,
      radMM200RxMinorAlarm1Mask,

```

```

        radMM200RxMinorAlarm2Mask
    }
    STATUS current
    DESCRIPTION "Demodulator non-volatile status group."
    ::= { mm200Groups 7 }

mm200DemodStatusGroup OBJECT-GROUP
    OBJECTS
        {
            radMM200RxMajorAlarm1Status,
            radMM200RxMajorAlarm2Status,
            radMM200RxMinorAlarm1Status,
            radMM200RxMinorAlarm2Status,
            radMM200RxLatchedMajorAlarm1Status,
            radMM200RxLatchedMajorAlarm2Status,
            radMM200RxLatchedMinorAlarm1Status,
            radMM200RxLatchedMinorAlarm2Status,
            radMM200RxMaxPayload,
            radMM200RxPercentUtilization,
            radMM200RxBandwidth,
            radMM200RxInputLevel
        }
    STATUS current
    DESCRIPTION "Demodulator volatile status group."
    ::= { mm200Groups 8 }

mm200DemodChannelNVStatusGroup OBJECT-GROUP
    OBJECTS
        {
            radMM200RxChannelNVIndex,
            radMM200RxChannelMajorAlarmMask,
            radMM200RxChannelMinorAlarmMask
        }
    STATUS current
    DESCRIPTION "Demodulator channel non-volatile status group."
    ::= { mm200Groups 9 }

mm200DemodChannelStatusGroup OBJECT-GROUP
    OBJECTS
        {
            radMM200RxChannelIndex,
            radMM200RxChannelMajorAlarmStatus,
            radMM200RxChannelMinorAlarmStatus,
            radMM200RxChannelLatchedMajorAlarmStatus,
            radMM200RxChannelLatchedMinorAlarmStatus,
            radMM200RxChannelBaudRate,
            radMM200RxChannelOffsetFrequency,
            radMM200RxChannelAGCIntegrator,
            radMM200RxChannelSNR,
            radMM200RxChannelCBA,
            radMM200RxChannelUBA,
            radMM200RxChannelInputLevel
        }
    STATUS current
    DESCRIPTION "Demodulator channel volatile status group."
    ::= { mm200Groups 10 }

mm200DemodInterfaceNVStatusGroup OBJECT-GROUP
    OBJECTS {
        radMM200RxInterfaceNVIndex,
        radMM200RxInterfacePID,
        radMM200RxInterfaceDataRate,
        radMM200RxInterfaceControl,
        radMM200RxInterfaceType,
        radMM200RxInterfaceSubType,
        radMM200RxInterfaceClockSource,
        radMM200RxInterfaceClockFrequency,
        radMM200RxInterfaceFraming,
        radMM200RxInterfaceVolume,
        radMM200RxInterfaceClockPolarity,
    }

```

```

        radMM200RxInterfaceDataInvert,
        radMM200RxInterfaceTerrestrialLoopback,
        radMM200RxInterfacePRBS,
        radMM200RxInterfaceMajorAlarmMask,
        radMM200RxInterfaceMinorAlarmMask,
radMM200RxInterfaceJitterControl,
radMM200RxInterfaceByteGapping
    }
    STATUS current
    DESCRIPTION "Demodulator interface non-volatile status group."
    ::= { mm200Groups 11 }

mm200DemodInterfaceStatusGroup OBJECT-GROUP
    OBJECTS
        {
            radMM200RxInterfaceIndex,
            radMM200RxInterfaceMajorAlarmStatus,
            radMM200RxInterfaceMinorAlarmStatus,
            radMM200RxInterfaceLatchedMajorAlarmStatus,
            radMM200RxInterfaceLatchedMinorAlarmStatus
        }
    STATUS current
    DESCRIPTION "Demodulator interface volatile status group."
    ::= { mm200Groups 12 }

mm200CommonNVStatusGroup OBJECT-GROUP
    OBJECTS
        {
            radMM200CommonControlMode,
            radMM200CommonLastRateControl,
            radMM200CommonUserMode,
            radMM200CommonFrequencyPlan,
            radMM200CommonAlarm1Mask,
            radMM200CommonAlarm2Mask,
            radMM200CommonResetSNMP,
            radMM200CommonLatchedAlarmsClear
        }
    STATUS current
    DESCRIPTION "Common non-volatile status group."
    ::= { mm200Groups 13 }

mm200CommonStatusGroup OBJECT-GROUP
    OBJECTS
        {
            radMM200CommonAlarm1Status,
            radMM200CommonAlarm2Status,
            radMM200CommonLatchedAlarm1Status,
            radMM200CommonLatchedAlarm2Status
        }
    STATUS current
    DESCRIPTION "Common volatile status group."
    ::= { mm200Groups 14 }

mm200CommonNotificationsGroup NOTIFICATION-GROUP
    NOTIFICATIONS {
        radMM200ColdStartTrap,
        radMM200AuthenticationFailureTrap
    }
    STATUS current
    DESCRIPTION
        "The two notifications which an SNMPv2 entity is required to
        implement."
    ::= { mm200Groups 15 }

mm200ModNotificationsGroup NOTIFICATION-GROUP
    NOTIFICATIONS {
        radMM200ModMajorAlarmTrap,
        radMM200ModMinorAlarmTrap,
        radMM200CommonAlarmTrap
    }

```



```
    }
    STATUS current
    DESCRIPTION "Modulator traps group."
    ::= { mm200Groups 16 }

mm200DemodNotificationsGroup NOTIFICATION-GROUP
    NOTIFICATIONS {
        radMM200DemodMajorAlarmTrap,
        radMM200DemodMinorAlarmTrap,
        radMM200CommonAlarmTrap
    }
    STATUS current
    DESCRIPTION "Demodulator traps group."
    ::= { mm200Groups 17 }

END
```



Glossary

G

A	
A	Ampere
AC	Alternating Current
ADC	Analog to Digital Converter
AGC	Automatic Gain Control
AIS	Alarm Indication System. A signal comprised of all binary 1s.
ANSI	American National Standards Institute
ASCII	American Standard Code for Information Interchange
ASIC	Application Specific Integrated Circuit
ATE	Automatic Test Equipment
B	
BER	Bit Error Rate
BERT	Bit Error Rate Test
Bit/BIT	Binary Digit or Built-In Test
BITE	Built-In Test Equipment
bps	Bits Per Second
BPSK	Binary Phase Shift Keying
Byte	8 Binary Digits
C	
C	Celsius
CATS	Computer Aided Test Software
CA/xxxx	Cable Assembly
CD-ROM	Compact Disk – Read Only Memory
CLK	Clock
cm	Centimeter
COM	Common
CPU	Central Processing Unit
CRC	Cyclic Redundancy Check. A system of error checking performed at the transmitting and receiving stations.
CW	Continuous Wave
C/N	Carrier to Noise Ratio

D	
DAC	Digital to Analog Converter
dB	Decibels
dBc	Decibels Referred to Carrier
dBm	Decibels Referred to 1.0 milliwatt
DC	Direct Current
DCE	Data Communications Equipment
Demod	Demodulator or Demodulated
DPLL	Digital Phase Locked Loop
DTE	Data Terminal Equipment
DVB	Digital Video Broadcast
D&I	Drop and Insert
E	
E_b/N_0	Ratio of Energy per bit to Noise Power Density in a 1 Hz Bandwidth.
EEPROM	Electrically Erasable Programmable Read Only Memory
EIA	Electronic Industries Association
EMI	Electromagnetic Interference
ESC	Engineering Service Circuits
ET	Earth Terminal
F	
F	Fahrenheit
FAS	Frame Acquisition Sync. A repeating series bits which allow acquisition of a frame.
FCC	Federal Communications Commission
FEC	Forward Error Correction
FIFO	First In, First Out
FPGA	Field Programmable Gate Arrays
FW	Firmware
G	
g	Force of Gravity
GHz	Gigahertz
GND	Ground

H	
HSSI	High Speed Serial Interface
HW	Hardware
Hz	Hertz (Unit of Frequency)
I	
IBS	Intelsat Business Services
IDR	Intermediate Data Rate
I/O	Input/Output
IEEE	International Electrical and Electronic Engineers
IESS	INTELSAT Earth Station Standards
IF	Intermediate Frequency
INTELSAT	International Telecommunication Satellite Organization
ISO	International Standards Organization
J	
J	Joule
K	
Kbps	Kilobits per Second
Kbys	Kilobytes per Second
kg	Kilogram
kHz	Kilohertz
Ksps	Kilosymbols per Second
L	
LCD	Liquid Crystal Display
LED	Light Emitting Diode
LO	Local Oscillator
M	
mA	Milliampere
Mbps	Megabits per Second
MFAS	Multi-Frame Acquisition Sync. See FAS.
MHz	Megahertz
MIB	Management Information Base
Mod	Modulator or Modulated
ms	Millisecond
M&C	Monitor and Control

N	
NC	Normally Closed
NO	Normally Open
ns	Nanoseconds
NVRAM	Non-Volatile Random Access Memory
N/C	No Connection or Not Connected
O	
OQPSK	Offset Quadrature Phase Shift Keying
P	
PC	Personal Computer
PLL	Phase Locked Loop
ppb	Parts per Billion
ppm	Parts per Million
P/N	Part Number
Q	
QAM	Quadrature Amplitude Modulation
QPSK	Quadrature Phase Shift Keying
R	
RAM	Random Access Memory
RF	Radio Frequency
ROM	Read Only Memory
rms	Root Mean Square
RU	Rack Unit. 1 RU = 1.75"
Rx	Receive (Receiver)
RxD	Receive Data
R-S	Reed-Solomon Coding. Reed-Solomon codes are block-based error correcting codes with a wide range of applications in digital communications and storage.
S	
SEQ	Sequential
SYNC	Synchronize

T	
TBD	To Be Designed or To Be Determined
TM	Technical Manual
TPC	Turbo Product Codes
TRE	Trellis
Tx	Transmit (Transmitter)
TxD	Transmit Data
U	
UART	Universal Asynchronous Receiver/Transmitter
UUT	Unit Under Test
V	
V	Volts
VAC	Volts, Alternating Current
VCO	Voltage Controlled Oscillator
VDC	Volts, Direct Current
VIT	Viterbi Decoding
W X Y Z	
W	Watt
Misc.	
μs	Microsecond
Ω	Ohms
16QAM	16 Quadrature Amplitude Modulation
8PSK	8 Phase Shift Keying

